

# Chapter Six

## *The Energy Discriminating X-ray Detector*

### 6. Introduction

The previous chapter presented the fundamental principles that constitute the basis for quantitative chemical analysis by EPMA techniques. Use of the Bragg equation to discriminate (separate) x-rays with a focusing x-ray spectrometer and direct a specific x-ray wavelength to a proportional detector, has a long and successful history. The advantages of WDS analysis include high resolution (in terms of wavelength separation) and relatively high peak to background ratios for a wide range atomic numbers. Care should be used when determining locations to measure WDS background, but once the proper locations are determined, background measurement and subtraction is generally straightforward. The disadvantage of WDS analysis is that it is relatively slow, primarily because the number of elements that can be analyzed simultaneously is restricted to the number of WDS spectrometers that can be placed around the electron column.

Our previous discussion of gas proportional detectors demonstrated that the detector itself has some capability of separating x-ray photons into discrete electronic pulses based on the energy of the x-ray photon. The energy discriminating capability of a gas detector is not very good, and is used mainly in conjunction with the PHA to resolve gross energy differences of noise and photon signals, with some possibility for separating higher order reflections with their resultant higher energies. It does, however, at least indicate the possibility of separating x-rays solely on the basis of their energy -- thereby eliminating the need for crystal (i.e., Bragg) diffraction altogether. The idea here is that if a detector and its associated electronics could be made sensitive enough, it should be possible to collect all x-rays simultaneously and sort them according to the energy of the electronic pulses they create in the detector. This is the fundamental basis for an *Energy Dispersive Spectrometer (EDS)*.

The key component of an EDS system is obviously the detector itself and more specifically, the character of the "active" charge-producing material within the detector. The problem with inert gases such as argon is that ionization requires a relatively large amount of energy (i.e., 27 eV) and hence the detector's energy resolution is relatively poor. The search for a more efficient charge-producing detector material coincided with the technological revolution resulting from the remarkable properties of semiconductors. Indeed, the properties of solid semiconductors such as silicon or germanium are ideal charge-producing, detector materials. They are ideal for detecting not only x-rays but also high-energy backscattered electrons.

WDS is generally the technique of choice for *quantitative* analysis, especially minor and trace element quantitation, but what if we do not require a quantitative analysis, but only need to know which elements are present? Or, maybe we only need to know which elements are present, and the approximate weight fractions. The EDS technique is the tool of choice for *qualitative* determinations because it is nearly instantaneous. An additional problem with WDS is the requirement to know *a priori* which elements to measure. EDS, on the other hand, can either qualitatively determine the elements that should be measured by displaying them, or it can qualitatively identify the phase (mineral) thereby leading the analyst toward which elements (major, minor and trace) should be measured. While a high resolution WDS wavelength scan can take up to 30 minutes to complete, the EDS spectrum is acquired in a few seconds. That is, the analyst can watch the whole spectrum accumulate and therefore determine all major elements and perhaps identify the phase in a matter of seconds; qualitative determination of minor elements can be accomplished in a matter of minutes.

Since the solid-state EDS detector was first introduced in 1968 it has been improved considerably. Resolution has improved from 500eV to 150eV<sup>1</sup> to less than 115eV today, thus making interferences (peak overlaps) easier to correct. Computers have come a long way as well, and this has greatly increased the speed in resolving peak interferences and background modeling. EDS can be quantitative. Its spectrum is not straightforward and is fraught with *artifacts*, but it can be as quantitative as WDS if great care is taken. Hopefully, rather than dogmatically influencing you to choose WDS over EDS for quantitative analysis, by the end of this section you will have an appreciation and the knowledge for how to properly evaluate EDS spectra, quantitatively and qualitatively. EDS systems (the detector and its associated computing hardware and software) are sold today with every promise of being as quantitative (and sensitive) as WDS. For many elements and some specimens this can be true, however the technique demands more attention from the analyst and is not likely to be as generally applicable to all specimens or as many elements. Regardless of one technique's capabilities over the other, a student should expect he or she will become involved with an SEM/EDS facility. Hopefully, the facility might have been able to afford at least one WDS spectrometer. However, even with available WDS it is sometimes unavoidable to use the EDS quantitatively.

## 6.1 The EDS detector

The most important criterion for any x-ray detector (as we saw with the gas filled detector for WDS) is that the output pulse should be a measure of the input pulse, i.e., the voltage pulse out of the detector and into an x-ray counter, should be a measure of the energy of the incoming photons. The proportionality between energy of the incident photon and the number of charges produced must be considerably better than is the case with gas counters. Reduced to its simplest components, an EDS detector works on the same principles as a gas

---

<sup>1</sup> EDS resolution has been standardized for the FWHM of Mn K $\alpha$  or an Fe<sup>55</sup> source (5.9 keV).

proportional detector, but it must be capable of better energy resolution. We can summarize the major requirements of an EDS detector as follows:

- (a) The detector must absorb x-rays efficiently and yet be of small size so it can be placed close to the x-ray source. A solid, rather than a gas or a liquid detector is indicated.
- (b) It must produce a large number of charge carriers each time a photon is absorbed so that the signal is reasonably strong prior to amplification (which always broadens the energy distribution). To give you some appreciation for the choice of solid semiconductors consider that the ionization energy for argon is 27 eV. This means, for example, that 64 (1740/27) pieces of information go into composing a 1.74 keV Si  $K\alpha$  peak for the WDS single-channel analyzer. In contrast, a silicon solid-state detector requires only 3.7 eV for charge production and a germanium detector requires only 2.9 eV. Therefore an EDS Si  $K\alpha$  peak can be composed of 470 (1740/3.7) or 600 (1740/2.9) pieces of information when collected with a silicon or germanium detector respectively. In the end, just how well a peak is defined (good resolution) is based on how much information was used to construct it.
- (c) The detector and pulse processing electronics must be capable of very high count rates because the EDS detector receives **all** x-rays directed toward it, rather than only those diffracted to it by a crystal spectrometer.

The only materials with these special properties are semiconducting crystals of silicon and germanium. The electrical conductivity of semiconductor crystals is best explained in terms of the energy levels available for electrons as indicated in Figure 6-1. Normally, most of the electrons in the semiconductor are at an energy level that corresponds to the valence band (covalent). However, a certain fraction can be excited to the level of the conduction band by thermal

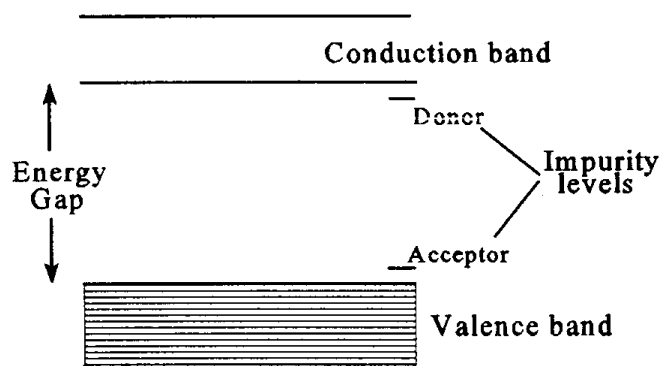

Figure 6-1. Energy levels for electrons in a semiconductor.

excitation (undesirable for our purposes), or by excitation from incident x-ray photons. The energy gap is 1.09 eV in silicon and 0.60 eV in germanium. Electrons in the conduction band are relatively free to move under the influence of an imposed electric field gradient, and this is what gives semiconductors their conductivity.

When an x-ray photon strikes a semiconductor detector it raises some electrons to the conduction band and leaves an *electron hole* in the valence band. Because the presence of an electron hole in the valence band is unstable, it attracts an electron from the valence band of a neighboring atom, leaving an electron hole in that atom which is filled from the valence band of its neighbor and so on. If an electric gradient is applied across the detector, the net result is a migration of the conduction band electrons toward the anode and migration of the electron

holes toward the cathode. The latter mode of describing this type of conduction is usually adopted and the electron hole is designated as (+). It turns out that the valence band electron holes are nearly as mobile as the electrons in the conduction band. Therefore both are efficient charge carriers under the influence of an applied field (contrast this situation with a gas counter where the  $\text{Ar}^+$  is much less mobile than the electrons). The combination of e-/ (+) pairs in the semiconductor crystal is the equivalent of  $\text{Ar}^+/\text{e}^-$  pairs in the gas detector. Although the energy gap in silicon is only 1.09 eV the average energy loss suffered by an x-ray photon while creating an e-/ (+) pair is 3.7 eV because some of the energy is also spent in increasing crystal lattice vibrations (a process not encountered in a gas detector). The number of e-/ (+) pairs created per photon is given by the energy of the x-ray photon/3.7 eV for a silicon detector. For example, an Mg  $K\alpha$  photon has an energy of 1,250 eV. When this photon strikes a silicon detector it will produce 338 e-/ (+) pairs, compared to 46  $\text{Ar}^+/\text{e}^-$  pairs in a gas detector.

The use of a semiconducting crystal as an x-ray detector is based on the fundamental property that the crystal has a well-defined, uniform energy gap between the valence band and the conduction band. To be "well-defined" (i.e., with a known and constant production of e-/ (+) pairs per photon energy) the crystal must be "perfect" without any impurities, and can thus be characterized by its *intrinsic* energy gap. Until very recently, it has not been possible to grow perfectly pure crystals and nearly all commercial crystals contain small but finite amounts of chemical impurities. A contaminant atom may have more valence electrons than silicon or germanium. For example, P, As, Sb usually contribute 5 e- to chemical bonds as  $\text{P}^{+5}$ ,  $\text{As}^{+5}$ , and  $\text{Sb}^{+5}$ . When such an atom is substituted for  $\text{Si}^{4+}$  in the silicon lattice, four of the valence electrons form the usual tetrahedral bond, but the "extra" electron is more loosely held and is consequently more like a conduction band electron than a valence band electron. In terms of band theory, the presence of these *donor* impurities is said to create a localized donor energy level just below the conduction band level (c.f., Fig. 6-1). Since electrons at that energy level need very little extra energy to jump to the conduction band, crystals with such impurities will be more conductive (i.e., create more e-/ (+) pairs) than the pure semiconductor crystal. A region of a semiconductor crystal with donor impurities is known as an *n-type* region because *n*egative electrons are the main charge carriers in such regions. In essence such regions of the crystal are characterized by an increased electron density relative to the pure crystal.

A contaminant atom may also have fewer valence electrons than the pure semiconductor. For example, B (a common contaminant in silicon) usually contributes only 3 e- to chemical bonds. When such an atom is substituted for  $\text{Si}^{4+}$  in the silicon lattice, there is a missing electron in the bond of  $\text{B}^{+3}$  with its four neighbors. In terms of band theory, the presence of these *acceptor* impurities is said to create a localized acceptor energy level just above the valence band level. Since electrons in the valence band need very little energy to jump into the acceptor level and create an electron hole in the valence band, crystals with such impurities will also be more conductive than the pure semiconductor. A region of a semiconductor crystal with donor impurities is known as an *p-type* region because *p*ositive

electron holes are the main charge carriers in such regions. In essence, such a region of the crystal can be considered to have a lower electron density than the pure crystal.

So how do we ever get around the inherent problems associated with "real-world" impurities? Clever chemistry comes to our rescue. It was recognized fairly early on in detector technology that if a near-perfect compensation between acceptors and donors could be brought about, the impure crystal would regain the electrical properties of those intrinsic to the pure crystal. This is done by compensating for the excess  $B^{+3}$  by doping the crystal with Li. Such a doped silicon crystal is labeled as Si(Li) (a "silly" crystal). Li is highly

mobile and can be diffused or "drifted" into a p-type region of a silicon crystal. It is a good electron donor because it has only one "loosely" held valence electron. By diffusing Li into the p-type region it is possible to "neutralize" all of the electron holes and eliminate all of the (+) charge carriers. Thus purged of its (+) charge carriers, the zone of "Li-drifted" silicon regains its *intrinsic* properties and "behaves" as if it were pure. The doping/drifted process is done electrochemically at elevated temperatures just after the crystal has been manufactured. After Li has diffused through the crystal and an electrical gradient is applied to the crystal, a thin region of n-type material will form at the anode. In this region Li is oxidized to  $Li^+ + e^-$ . A thin layer next to the cathode remains a p-type region, and the bulk of the crystal in the middle is rendered intrinsic. This is schematically illustrated in Figure 6-2. The semi-conductor is sandwiched between two conductive layers of gold and a high voltage potential is placed on these layers. The HV is necessary in order to attract the electrons to the anode and the electron holes to the cathode.

There is no way that  $e^-/+$  pairs can be amplified by a process such as *gas amplification* as in the gas-filled detector. Therefore the EDS detector relies instead on an intimately bonded *field-effect transistor (FET)* to amplify the pulse linearly and to pass it on to the preamplifier which is also part of the EDS detector assembly.

Prior to 1993, all x-ray detectors were lithium-drifted silicon, Si(Li). Germanium as a detector material had previously been ruled out because of poor resolution for lighter elements, ( $keV < 2$ ; thought to be inherent at the time) and were instead used only for measuring high energy radiation such as gamma rays. In 1993, however, Oxford Instruments introduced, a new germanium EDS detector which delivers resolution for Mn  $K\alpha$  of 110eV and better for

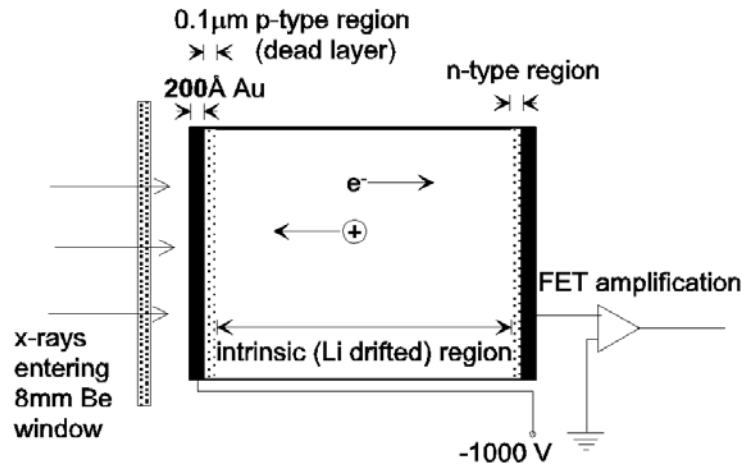
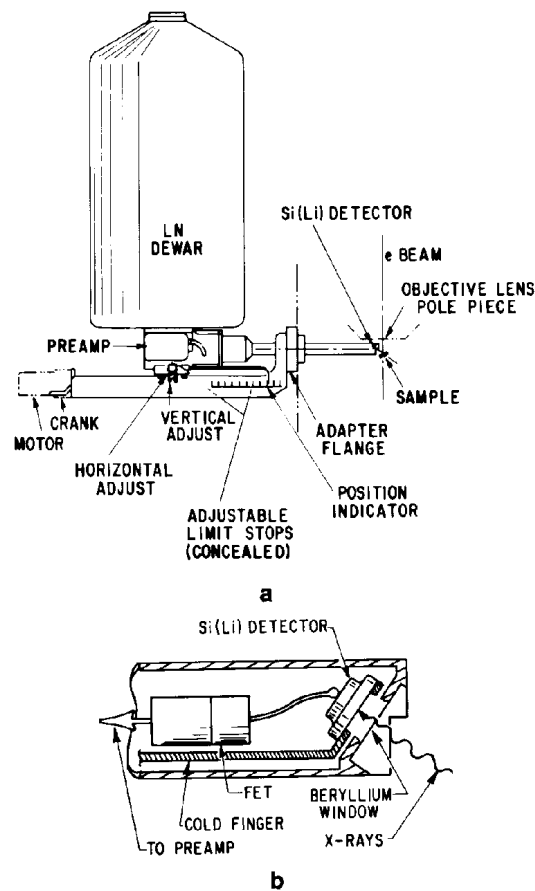

Figure 6-2. Details of a solid-state, semiconductor x-ray detector.

lighter elements. Today, Si and Ge can be manufactured pure enough to reduce the need for the lithium donor. The excellent resolution which is evident in the newest detectors is a result of an extremely consistent energy band which defines its semi-conductivity. In any case, both our JEOL SEM and CAMECA EPMA have the more standard Si(Li) detector. The main advantage is that the Si(Li) detector does not have to be kept at liquid nitrogen temperatures all the time. It can be warmed up so long as the bias voltage is turned off, without being destroyed. This has advantages in a shared user facility, where mistakes are part of the learning process.

The main components of an EDS detector are shown in Figure 6-3. The detector is enclosed in its own vacuum, isolated from the specimen chamber with a detector window, and maintained at liquid nitrogen temperatures with a cold finger and liquid nitrogen dewar. The crystal itself is quite small - typically a wafer with an area of approximately  $10\text{mm}^2$  and a thickness of  $1\text{mm}$ . Examination of the diagram shows that an x-ray has to pass through three layers before given the opportunity to generate its pulse within the intrinsic region of the detector. If the x-ray isn't absorbed by the specimen, it may be absorbed by the detector window, which is typically 5 to  $10\mu\text{m}$  of beryllium or aluminum coated polypropylene in the case of more modern detectors. It might also be absorbed by the  $200\text{\AA}$  gold conductive layer or the  $1000\text{\AA}$  dead layer on the detector surface. The gold is a component of the HV sandwich, and the *dead layer* is an inactive layer within the crystal, the thickness of which is attributable to the manufacturing procedure used to make the detector intrinsic and, to some degree, also attributable to the care given the detector and its age. All three of these layers can contribute something of their own to the x-ray spectrum. These artifacts will be taken up later in this chapter.



**Figure 6-3.** (a) Major components of a typical EDS detector system. (b) Details of the detector itself.

The crystal and FET are operated and maintained at liquid nitrogen temperature in order to 1) decrease the number of electrons in the conduction band produced by thermal agitation, and thereby reduce "electronic noise"; 2) decrease the noise from the FET-preamplifier; and 3) prevent the diffusion of  $\text{Li}^+$  which would be rapid at room temperature under the influence of the high potential across the crystal. If the crystal is ever allowed to heat up (to room temperature) while the high voltage across it is on, it will be seriously damaged or

ruined (at an expense of about \$15k). If the high voltage bias is disabled, then occasionally (once a year) it is generally beneficial to take the detector through a controlled warm-up cycle to allow any ice-build-up to be pumped off. Obviously this is not true for Ge based detectors, which should never be allowed to warm up.

It should also be mentioned here that the window which isolates the detector from the specimen and possible contamination is not necessary if the SEM's vacuum chamber is very clean. Ultra-thin windows and windowless detectors have been developed in order for low energy x-rays (B, O, N, C) to be counted. These detectors are usually provided with a window turret, that offers the analyst a choice of two (e.g., window in or out), or three (e.g., thick, thin, none) modes of operation. In any case, windowed, turreted or otherwise, great care must be taken to ensure that the detector itself is never exposed to atmospheric pressures and contamination, and that its protective window is never damaged. Care should also be taken in cleaning the detector's window. Oils and atmospheric water will condense on its cold surface and it should be cleaned often enough so that x-rays are not also absorbed inconsistently. Care should also be taken while cleaning so as not to damage the window's vacuum seal.

The signal from a WDS spectrometer gas detector after amplification is sent to the PHA, which rejects pulses outside a pre-defined "window". Only pulses falling within this window are sent to the "counter" for processing. In this sense, the PHA serves as a *single channel analyzer*, only recording pulses in a single voltage range (or a single window, or a single "channel"). In contrast, the EDS output is stored in multiple channels of pre-determined width corresponding to a particular range of energy. An EDS detector system is therefore directly coupled to a *multi-channel analyzer (MCA)*. The purpose of the MCA is to accumulate the number of pulses produced by the detector that fall within a pre-determined energy range.

It is important not to be misled by the seemingly high energy resolution (e.g., 110 eV) available on state-of-the-art EDS detectors. Although impressive, this resolution is still considerably less than that of a well-tuned WDS system. WDS can resolve x-ray lines with a *full width at half maximum* (FWHM) less than 20eV, which allows for few peak interferences and for background intensities to be simply measured. For example, although Mn K $\beta$  ( $E=6.492\text{keV}$ ,  $\lambda=1.909\text{\AA}$ ) is very near Fe K $\alpha$  ( $E=6.400\text{keV}$ ,  $\lambda=1.937\text{\AA}$ ), the interference is very, very small ( $\sim 0.2\%$ ), i.e., Mn K $\beta$  counts will not contribute to Fe K $\alpha$  in a typical WDS analysis. On the other hand, the peak width of the Fe K $\alpha$  as measured by an EDS detector is approximately 160eV. Practically speaking, Mn K $\beta$  is right on top of the Fe peak and interferes significantly in the EDS detector.

WDS doesn't demand particularly good resolution of the gas filled detector because the Bragg crystal geometry allows only the x-ray wavelength of interest, or integral multiples of a competing x-ray, to pass into the detection electronics and counter. The EDS detector doesn't have this luxury, and hence many elements might confuse, or hide, the presence of others if peak overlap is significant. All of the processes occurring in a gas or solid-state detector produce peaks of finite width, even though an incoming x-ray photon is essentially *monochromatic*. Thus in a Si(Li) detector, even though the band-gap is only 1.09eV, the *average* expenditure of energy in creating an e-/(+ pair is 3.7eV. Some events expend more

than 3.7 eV and others less, thus resulting in a spread in energy of the resulting pulse. For quantitative analysis we would have to consider the area under a given peak, and this involves consideration of peak height, width and shape. Figure 6-4 illustrates these potential problems in more detail. This figure shows an EDS x-ray spectrum for KCl. Note that the chlorine  $K\alpha$  "peak" is not resolved from the  $K\beta$  peak. Although the separation is better for the potassium peaks, the two peaks cannot be considered to be separate. You should also notice that the peaks have either unique shapes or are recognized as pairs. In the case of L and M lines, we often see a whole "family" of overlapping peaks. Any attempt to obtain quantitative analyses from an EDS spectrum must necessarily deal with integration of peak areas. Obviously this integration must also include modeling of the ideal spectrum by subtracting (separating) overlapping peaks. This procedure is computer intensive and also not perfectly exact. Reference to Figure 6-4 should also convince you that it is often not possible in a typical EDS spectrum to unambiguously recognize where to measure the background. In practice, the computer software ends up modeling the complete background in an iterative fashion and then subtracting this "synthetic" background from the peaks of interest. For these reasons and including the degree of difficulty of providing any confidence or an error associated with peak deconvolution and background subtraction, WDS remains the choice for quantitative analyses.

## 6.2 Characteristics of EDS spectra

A gas detector in conjunction with a PHA on a WDS system effectively isolated the "peak" of interest, and the analyst can typically ignore all of the other processes that produce "artifacts" (e.g., Ar escape peaks). EDS analysis, however, requires attention to everything taking place within the detector. It is therefore necessary for us to describe some of these processes and their resulting artifacts.

### 6.2.1 Incomplete charge collection

*Incomplete charge collection* might be considered the result of one of *Murphy's corollaries* stating that "nothing happens as perfectly as you might like", or "no process is 100 percent efficient". The gas-filled detector is example of this rule; although incoming x-rays are virtually monochromatic, the detector always produces a statistical distribution of voltages which is skewed toward lower voltages. This is an indication that the charge-producing process is inefficient. This inefficiency may

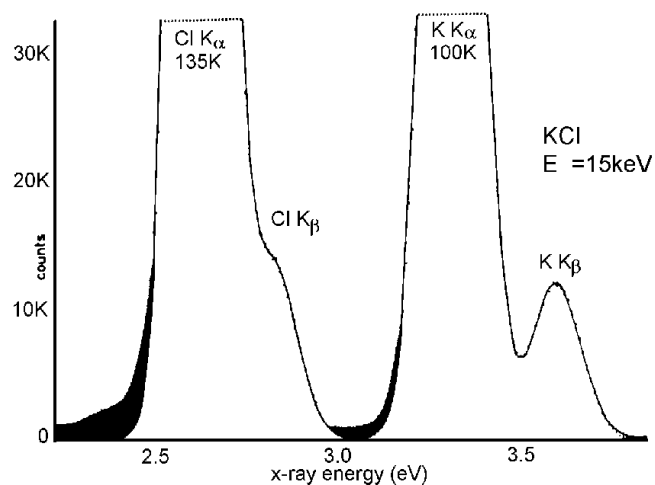

**Figure 6-4.** The EDS spectrum of potassium chloride. The K peaks are apparent but are not resolved. Also note the low-energy "shelves" which are due to incomplete charge collection.

be attributable to having fluoresced Ar x-rays or  $\text{Ar}^+$  ions not recombining quickly enough to keep up with high input rates. In either case, the number of charge carriers assumed to be representative of the incoming x-ray's energy is actually somewhat less than the theoretical value. This inefficiency within the gas detector is analogous to what, in EDS terminology, is referred to as *incomplete charge collection*. The result is pretty much the same, x-ray energy distributions that are skewed towards lower energy and an indication the number of charge carriers produced by an incoming x-ray is not quite up to 100% efficiency.

Figure 6-5 shows an actual energy distribution and a calculated (*ideal*) Gaussian distribution. The skewness is apparent as a shelf of higher-than-ideal background counts on the low energy side of the peak. These counts are indicative of inefficient photoelectron production and incomplete charge collection. The degree of efficiency is a function of x-ray energy and is more pronounced for low Z elements (e.g., Na to K). The actual process which is assumed to be responsible is an x-ray such entering the intrinsic region, but being absorbed by the photo-electron-producing process early enough that some of the photo-electrons enter the detectors *dead* region and are not able to be included in the electron migration and counted as part of the pulse. Energetic x-rays (from higher Z elements), on the other hand, penetrate far enough into the intrinsic region that the photo-electron producing process is almost 100% efficient.

At first glance, the problems associated with incomplete charge collection might seem minor.

Unfortunately they are not. Although elements are still quite easily identified and there is no significant loss of energy resolution, there are significant problems associated with quantifying or integrating the peaks precisely. For example, x-ray

counts which should be associated with and found within the energy range which defines the *window* for that peak may now be found outside the window and the integration is inaccurately too low. Second, if the computer integration algorithm assumes a Gaussian shape for the peak of interest, the integration will not be accurate because of the inappropriate peak-shape assumption. Lastly, the x-ray peak's low energy "shelf" which is the result of incomplete charge collection does not represent true background and would be one of the wrong places to evaluate the background continuum. Very few computer algorithms can account for this phenomenon accurately. Since this problem is not a function of count rates, the best way is to integrate an *incomplete* peak with a model or assumptions based on the shape of a real peak rather than assuming a symmetrical distribution.

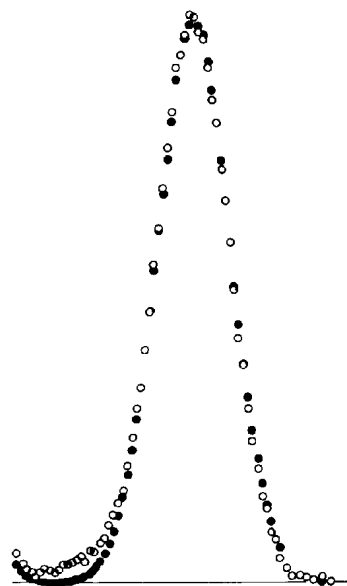

**Figure 6-5.** Illustration of incomplete charge collection. Filled circles correspond to a calculated Gaussian distribution. Open circles are actual data. Note low-energy shoulder on the peak.

## 6.2.2 The Silicon escape peak

We saw earlier that for ionization within an argon-filled gas detector the possibility exists for generating an argon K x-ray and then having that x-ray escape from the detector. This event results in a loss of energy to the counting system (i.e., less than complete energy conversion), and production of an "artifact" Ar-escape peak in the spectrum. The same possibility exists for x-rays entering a solid state detector with an energy exceeding the critical excitation energy of silicon (1.838keV)<sup>2</sup>. That is silicon K $\alpha$  x-rays will be generated, rather than only electron/hole pairs. Ideally, this x-ray will remain in the semiconducting crystal and ionize other electron/hole pairs still in keeping with conservation of energy. However, there is a finite possibility that the x-ray will escape the detector. If this does occur then there will be pulse measured from the detector that represents the energy of the incoming x-ray minus the energy of the "escaped" Si K $\alpha$  photon (1.74keV). The table below lists Si escape peaks for elements of interest and the possible confusion they might cause.

element (Z)	Energy of K $\alpha$ peak	Energy of escape peak	intensity of escape peak (%)	other K $\alpha$ peaks close to escape peak
P (15)	2.013	0.274	1.40	B (185eV), C (282eV)
S (16)	2.307	0.568	1.30	O (523eV)
Cl (17)	2.622	0.882	1.20	none
K (19)	3.313	1.573	0.91	Al (1.487 keV)
Ca (20)	3.690	1.951	0.78	P (2.013)
Sc (21)	4.089	2.349	0.67	S (2.307)
Ti (22)	4.509	2.769	0.57	none
V (23)	4.950	3.210	0.48	none
Cr (24)	5.412	3.672	0.40	Ca (3.690)
Mn (25)	5.895	4.155	0.33	Sc (4.089)
Fe (26)	6.400	4.659	0.28	none
Co (27)	6.925	5.185	0.23	none
Ni (28)	7.472	5.732	0.19	none
Cu (29)	8.041	6.301	0.16	Fe (6.400)
Zn (30)	8.631	6.891	0.13	Co (6.925)

Note in particular that a mineral containing both K and Al, will exhibit a Si-escape peak caused by K K $\alpha$  x-ray that will overlap with the Al K $\alpha$  peak. Similar interferences exist for Cr - Ca, Cu - Fe and others as noted in the table. The fourth column, which lists the intensity of the escape peak relative to the peak to which it should belong, shows a decreasing significance of the artifact with increasing atomic number. This, as you might suspect, is because higher energy x-rays ionize deeper within the detector and the probability of escape is decreased. In

<sup>2</sup> We will use a silicon detector for this discussion. It should be apparent that the same process will produce a germanium-escape peak if a germanium detector is used, at it's own corresponding distance (for Ge K $\alpha$ ) from the element of interest's peak energy.

spite of reduced significance, locations of possible escape peaks are no place to be evaluating the background continuum. Most computers provided with EDS systems are capable of anticipating and/or displaying escape peaks. Those computer systems claiming quantitative EDS capabilities, deal with escape-peak - analytical peak overlaps by subtracting the escape-peak counts from those corresponding to the peak of interest (e.g., the K{Si-escape peak} from the Al peak). Estimation of the intensity of the escape peak is based on the empirical intensity ratios listed in column four of the table. Unfortunately, these ratios depend on the individual detector, and hence are very imprecise to start with and unfortunately change as the detector "ages".

### 6.2.3 The Silicon fluorescence peak

One of the more interesting and enigmatic artifacts present in EDS spectra is the presence of a peak for silicon even in spectra collected on samples known to be completely devoid of Si. Figure 6-6 illustrates such a feature -- generally known as the *silicon fluorescence peak*. The figure shows a spectrum collected from pure carbon with a Si(Li) detector and a Be window. The Be window effectively absorbs all C K $\alpha$  x-rays, and hence we do not see a peak for C. What is perplexing is the fact that the spectrum shows a definite peak for Si. Superimposed on the high-count-rate, low-energy continuum is what is known as the *Si fluorescence peak*. What is generating a Si peak in a specimen composed of pure carbon? The Si peak cannot be the result of excitation of Si K $\alpha$  x-rays in the detector by C K $\alpha$  x-rays entering the detector because the energy of a C K $\alpha$  x-ray is less than  $E_C$  for Si. The only reasonable explanation for this peak is that it must be similar to the silicon-escape-peak phenomenon, except the Si K $\alpha$  x-ray is fluoresced entirely within the *dead* layer of the detector thus yielding no electron/hole pairs. However, the resulting Si K $\alpha$  x-ray then enters the intrinsic region of the detector where it creates the requisite number of electron/hole pairs. If we accept this explanation, we are still left with the question of what excited the Si photons. Textbooks give two possible causes: 1) Ionization of inner-shell Si K $\alpha$  x-rays by the continuum (background or Bremsstrahlung); and 2) Ionization of inner-shell Si K $\alpha$  x-rays by high-energy backscattered electrons entering the detector. Figure 6-6 illustrates that at the low-energy end of the spectrum, the intensity of the continuum

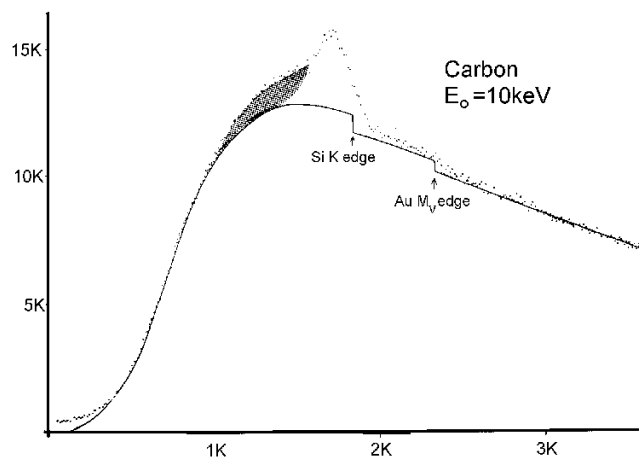

**Figure 6-6.** EDS spectrum collected on sample of pure carbon (dots) and a calculated background spectrum indicating absorption edges.

is considerable and it can indeed cause ionization of Si  $K\alpha$  x-rays in the detector. Furthermore, reference to Chapter 2 indicates that backscattered electrons also have sufficient energy to excite Si x-rays in the near-surface layers of the detector. We believe “fast” BSEs are actually the most likely culprit in producing this phenomenon.

The carbon spectrum exaggerates this phenomenon by indicating a significant Si peak. In practice this artifact probably contributes only about 0.2% to a typical Si analysis. This might be considered well within the technique's error, but should give you reason to suspect any EDS measurements of silicon at trace amounts in minerals such as oxides, sulfides or other non-silicates. For example, *minimum detection levels* are calculated statistically and are rarely checked against a real specimen. Statistically speaking, a WDS analyst might calculate a realistic detection limit for silicon of near 500ppm, and therefore feel comfortable in reporting Si at 1500ppm in a mineral such spinel. A knowledgeable analyst should be suspect of such claims based on EDS analysis.

#### 6.2.4 Absorption edges

The spectrum of carbon (Figure 6-6) also show a computer-calculated model for the continuum (background) which accounts for absorption of x-rays (characteristic and continuous) by the gold conductive layer as well as the silicon dead layer, and shows the absorption edges as sharp and well defined contributions to the spectrum. Accurate background modeling must also account for these edges. In practice, the edge heights vary, as a function of detector dead-layer thickness, depending on both detector fabrication and to some degree on the age of the detector. For the sake of accurate background measurement, and minor and trace element measurements, the EDS analyst should know how to account for artifacts such as internal silicon fluorescence and absorption effects. Such subtle effects, which might also include contamination precipitating on the detector window, can sometimes be accounted for by measuring the spectrum from pure diamond. Software is usually provided such that if it has a good carbon spectrum to work with, it can calculate parameters that can be used to model regions of complexity in the x-ray continuum.

## 6.2.5 Pulse pile-up

A solid-state, semiconducting detector differs significantly from gas proportional detector in terms of its "dead-time". Owing to the fact that electron (or electron hole) transfer from atom to atom is significantly faster in solids as opposed to gases, a solid-state detector itself has negligible dead-time (in the strict sense). Effectively the dead-time of an EDS detector is equal to, or shorter than, the rise time. This means that two x-ray photons entering the detector separated by a time interval less than the rise time will not register as separate pulses but will combine to create

a number of e-/(+ pairs proportional to their combined energies. In contrast to the gas detector, the energy of the second photon is not "lost". Instead, it is added to the energy of the initial photon. The resultant pulse sent to the amplifier and MCA is therefore representative of the sum of the energies of the two photons. The end-result is that a pulse is stored in an MCA channel that is not representative of the energy of either photon. Hence we have two potential problems caused by multiple incidences of x-ray photons into an EDS detector. 1) Counts are lost because they are not stored in their proper energy channels, and 2) extra counts are registered in energy channels representing the combined energy of the nearly coincident x-ray photons. The result in the x-ray spectrum display is an artifact peak at the energy location  $E_A + E_B$ . A number of such sum pulses stored in a particular energy channel constitute a spurious "sum peak". The phenomenon is referred to as *pulse pile-up* and can be reduced to nil if the counting electronics are properly adjusted and you stay below user-definable count rates (see section on electronics). The problem would be impossible to account for if two x-rays did actually arrive at the same time, but that is not probable given the speed of today's electronics technology.

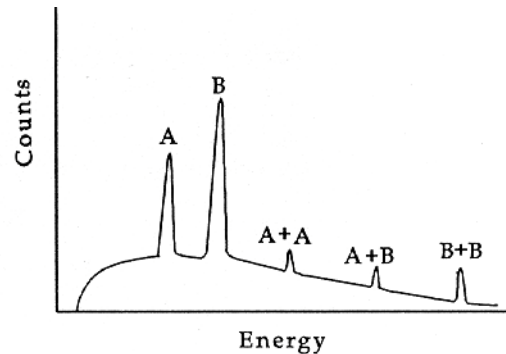

Figure 6-7. Spurious "sum peaks" caused by pulse pile-up.

Where previous spectral artifacts are attributable to detector "defects", *pulse pile-up* can be remedied with electronic processing. In order to compensate for a double event, the data must be recognized as "bad," and not counted. This is accomplished by placing a secondary amplifier with a very short time constant ( $\tau$ ) in parallel with the main amplifier. If this second amplifier detects two pulses separated by less than a set time interval it deactivates the ADC for the duration of the sum pulse and prevents the pulse from being counted in the MCA. Furthermore, the time it took to analyze the bad events must be added to the acquisition time. This subject leads this text into the next section that describes the analyst's influence on spectral acquisition.

In the case of a gas proportional detector, we saw that artifacts such as Ar-escape peaks could be removed from the final signal by electronic devices such as a PHA. The previous discussion illustrates that an EDS spectrum contains a wide variety of artifacts. Some of these are summarized in Figure 6-8 -- an EDS spectrum collected from a specimen composed of pure titanium metal.

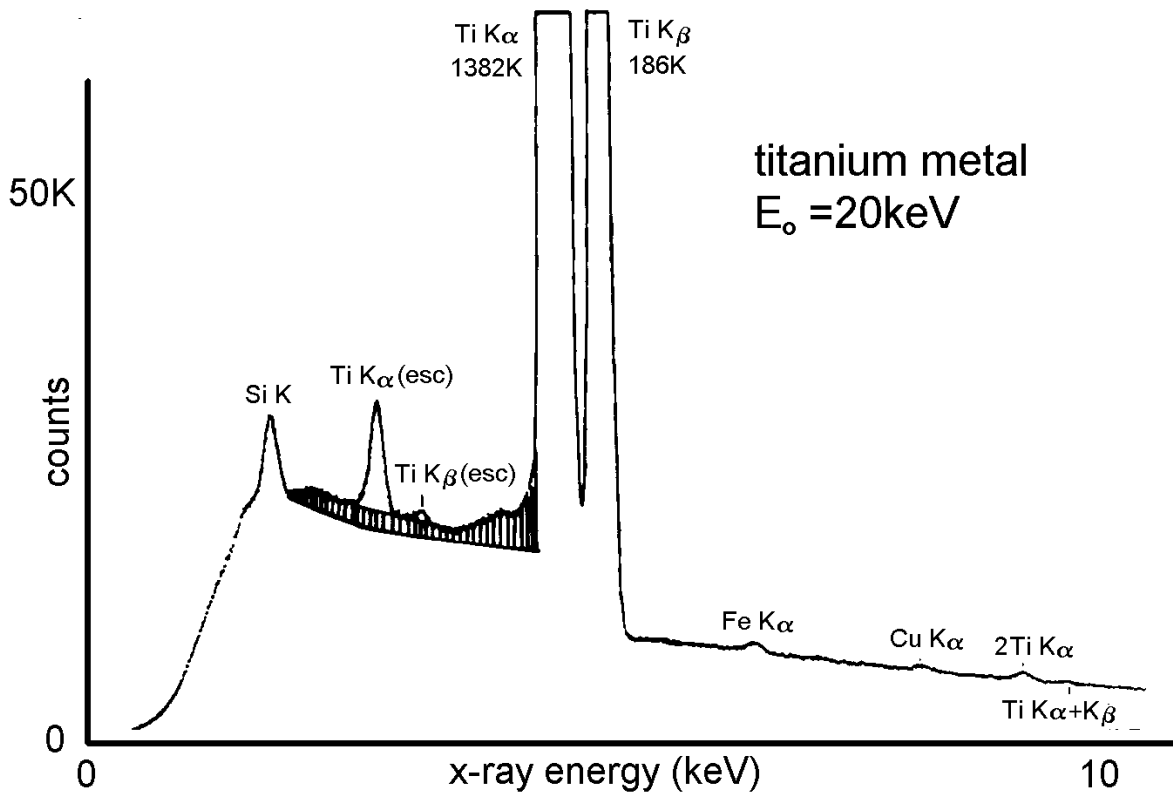

Figure 6-8 Electron -excited EDS spectrum of titanium. The Ti K and K, silicon x-ray escape peaks, and the 2K and (K+K) sum peaks are noted. Extraneous peaks from the specimen chamber are also observed

In principle, a pure Ti spectrum ought to be simple and straightforward. Figure 6-8 certainly does not fit that description! The artifacts are both numerous and complicated. The logical question is "*can any or all of these artifacts be removed by electronic processing after the signal has been generated in the solid-state detector*". The answer is largely no, although spectral processing can be used to improve the signal considerably.

### 6.3 EDS electronics and spectral processing

After an x-ray photon has created  $e^-/(+)$  pairs, the electrons are attracted to the anode and the electron holes are attracted to the cathode. As with gas detectors, when electrons strike the anode a momentary drop in the applied potential occurs. This is the signal that is ultimately measured. The fundamental principle is that the voltage of the initial signal is proportional to

the energy of the x-ray photon creating it. Owing to the fact that a solid-state detector cannot amplify the signal by itself (as can the gas detector), the initial pulse is extremely weak and must be amplified. We basically need a very sensitive electronic device that can amplify the original signal without destroying the proportionality or introducing unwanted noise. The most suitable device for this critical first-stage of amplification is known as a field-effect transistor (FET). As a transistor, the FET consists of three electrodes: a "source", a "gate" and a "drain". By including a fixed-resistor circuit in the FET, the device remains "charge sensitive" such that the output remains proportional to the charge of the incoming pulse. The output pulses have a sharp leading edge with a rise time of less than 100ns and an exponential tail.

After further amplification by a preamplifier and a linear amplifier, the EDS electronics must be capable of 1) measuring the strength of the pulse (this gives us E for photon identification), and 2) counting it as a contribution to the intensity, I (cps), of the peak. These two steps are carried out in what is known as a *multichannel analyzer (MCA)*. In order to determine pulse height (i.e., strength of the pulse) the signal is passed through an *analog-to-digital converter (ADC)*. This device converts the voltage of a pulse (analog) to time periods (digital). The operation of an ADC is quite simple; a capacitor is charged by an incoming pulse and then the capacitor is allowed to discharge at a constant rate. During the discharge period an

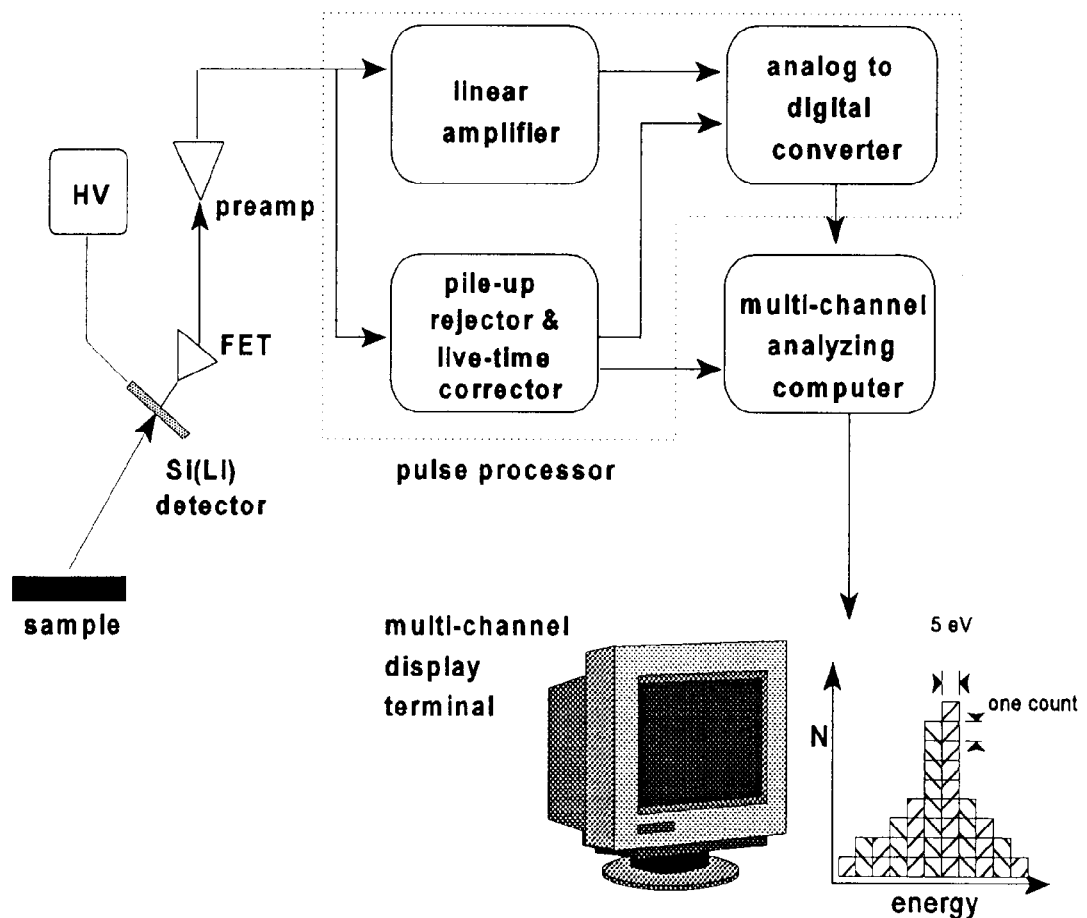

**Figure 6-9.** Block diagram illustrating the main components of an EDS x-ray detection system.

accurate electronic clock counts intervals. The number of intervals is proportional to the voltage of the pulse. The output of the ADC is thus digital (0 or 1), and the number of 0-1 pairs is a measure of the voltage of the incoming pulse.

When the ADC is through measuring the pulse height and converting the voltage to a digital signal it is sent to the MCA. Nowadays the MCA is simply a portion of computer memory reserved for data acquisition. The MCA consists of a number of "channels" -- older instruments were limited to 512 channels, the current standard is 1024 ( $2^{10}$ ) or 2048 ( $2^{11}$ ), and some systems are even capable of 4096 channels. The analyst has the option of defining the voltage range corresponding to a single channel. For example, if the MCA has a fixed number of 1024 channels and we are interested in collecting an x-ray spectrum spanning the range from 0 to 10 keV, we would define the MCA channel width to be 10.0 eV per channel. When a pulse is processed by the ADC, it is sent as a "packet" of "bits" to the MCA. The MCA then places that packet into the appropriate energy channel (memory address) defined by the number of bits in the packet. With time, each packet is placed into its appropriate memory register of the MCA reserved for pulses in that particular energy range. One by one the pulses are added into the proper energy "channels" of the MCA. The resulting energy histogram (number of pulses vs. energy) can then be displayed in real time on a CRT while the actual data are stored for future numerical processing within the computer.

The most important aspect of spectral processing is *time*. In a gas detector system, the main contributor to dead-time is the gas detector itself. In contrast, in an EDS system the detector is extremely fast and the dead-time actually results from the electronic circuitry. Indeed the *pulse pile-up rejector* purposely creates dead-time in order not to count spurious sum pulses. The pile-up rejector processes only the leading edges of incoming events and detects every pulse. If it detects two pulses separated by less than a set time interval, the *time constant*, it deactivates the ADC for the duration of the sum pulse and prevents the pulse from being counted in the MCA. In essence, the pile-up rejector shuts the counting system down for the periods of time corresponding to the arrival of piled-up pulses. The keyword is 'time'.

### 6.3.1 Dead time

In an EDS system "*Dead-time*" is the time it takes to measure a pulse plus any time it takes to recognize bad pulses and not count them. Dead-time, and its conjugate, *live-time*, are usually reported as a percentage; i.e. the system is alive and counting 75% of the time. The MCA is connected to a precise electronic clock that keeps track only of the "live-time" of the system during counting. With this system, any pulse above the noise level generates an "ADC is busy" signal that stops the clock until the pulse has been processed. The clock is also stopped during the deactivation for pulse pile-up rejection. Thus it accumulates only live counting time. This feature is clearly visible in watching a spectrum develop in real time on a CRT. Even for relatively low count rates, the acquisition time (live time) is much greater than real time. Dead-time can be controlled to a certain extent with adjustment of the main amplifier's time constant, but extremely high count rates can not be exceeded because it is possible to shut down processing altogether. Rejection logic takes over if pulses exceed certain rates. When this

occurs the analyst has no choice but to reduce the beam current and thereby decrease the number of x-rays entering the detector.

The analyst should be aware of the capabilities of a particular EDS system. The opportunity exists to make the spectral acquisition from a target's specific location quantitative, or optimal for elemental mapping. Processing *time constants* can be selected, usually as one of several, ranging from 1 to 16  $\mu$  seconds. The analyst might have available 5 choices, from long to short. Long time constants are for improved energy resolution and quantitative analysis, and short time constants are best for increased count rates and improved statistics for elemental mapping. Professor Heisenberg always wins!

A caution should be raised with regard to high count rates, rejection logic and elemental mapping. This type of acquisition is usually time consuming (several hours) because x-rays must be collected over a large area. Typically, the analyst will set up the instrument and then let it acquire data unattended. Be aware, if you optimize your count rates by collecting x-rays on a silicate mineral, the total count rate is likely to be moderate to low since most of its composition is oxygen which doesn't contribute to the count rate. If during the course of the mapping, the beam encounters a sulfide or native-metal mineral, the count rate will be so high that acquisition will essentially lock up (extremely high dead-time or low live-time). Upon return to the instrument at the time you anticipated it being finished, you may find that it hasn't progressed very far and you'll realize wasted time.

The analyst does have some control over time. He or she can adjust time parameters that improve the spectral resolution at the price of counting statistics, and vice versa. Improving counting statistics comes at the expense of time. If you want a spectrum to have good resolution you must give the processor enough time to analyze the pulse. Any impatience and desire for increased count rates invites pulse pile-up. However, with fast electronics, and a pile-up rejecter, it is possible to eliminate "bad events", and extend the acquisition time optimally.

### 6.3.2 Spectral processing

Processing of EDS spectra is problematic; not so much with regard to integrating and measuring x-ray peaks, but rather, on the many assumptions that are associated with the background continuum. Because of relatively poor energy resolution, for complex spectra an EDS can not show the analyst accurate locations for background determinations. An EDS computer will instead "model" and calculate the entire background continuum. With regard to minor elements and error evaluation, this is the most important spectral processing job.

The entire x-ray spectrum is represented to the analyst as 1024 channels, each a representation of the number of events of that energy per channel. Integration of an element of interest is defined as a *window* or a *region of interest (ROI)*, the width of channels is user determined. Windows then define integration for quantifying an unknown's elemental concentration relative to that of a standard. Windows also define the pixel by pixel integration

for an element's x-ray dot map. If window integrations need to be corrected for spectral interference it will be calculated based on the offending element's own window. Still, the most complex and uncertain calculation is the background continuum. Since background (i.e., the Bremstrahlung) is largely dependent on average atomic number, it will be most accurately modeled based on the target's composition. Its modeling is therefore an iterative process along with calculation of the weight fraction of the elements present.