The Penetration of a Fluid into a Porous Medium or Hele-Shaw Cell Containing a More Viscous Liquid

Author(s): P. G. Saffman and Geoffrey Taylor

Source: *Proceedings of the Royal Society of London. Series A, Mathematical and Physical Sciences*, Vol. 245, No. 1242 (Jun. 24, 1958), pp. 312-329

Published by: [The Royal Society](#)

Stable URL: <http://www.jstor.org/stable/100420>

Accessed: 28/08/2013 10:35

Your use of the JSTOR archive indicates your acceptance of the Terms & Conditions of Use, available at
<http://www.jstor.org/page/info/about/policies/terms.jsp>

JSTOR is a not-for-profit service that helps scholars, researchers, and students discover, use, and build upon a wide range of content in a trusted digital archive. We use information technology and tools to increase productivity and facilitate new forms of scholarship. For more information about JSTOR, please contact support@jstor.org.



The Royal Society is collaborating with JSTOR to digitize, preserve and extend access to *Proceedings of the Royal Society of London. Series A, Mathematical and Physical Sciences*.

<http://www.jstor.org>

The penetration of a fluid into a porous medium or Hele-Shaw cell containing a more viscous liquid

BY P. G. SAFFMAN AND SIR GEOFFREY TAYLOR, F.R.S.

Cavendish Laboratory, University of Cambridge

(Received 17 January 1958—Read 17 April 1958)

[Plates 2 and 3]

When a viscous fluid filling the voids in a porous medium is driven forwards by the pressure of another driving fluid, the interface between them is liable to be unstable if the driving fluid is the less viscous of the two. This condition occurs in oil fields. To describe the normal modes of small disturbances from a plane interface and their rate of growth, it is necessary to know, or to assume one knows, the conditions which must be satisfied at the interface. The simplest assumption, that the fluids remain completely separated along a definite interface, leads to formulae which are analogous to known expressions developed by scientists working in the oil industry, and also analogous to expressions representing the instability of accelerated interfaces between fluids of different densities. In the latter case the instability develops into round-ended fingers of less dense fluid penetrating into the more dense one. Experiments in which a viscous fluid confined between closely spaced parallel sheets of glass, a Hele-Shaw cell, is driven out by a less viscous one reveal a similar state. The motion in a Hele-Shaw cell is mathematically analogous to two-dimensional flow in a porous medium.

Analysis which assumes continuity of pressure through the interface shows that a flow is possible in which equally spaced fingers advance steadily. The ratio $\lambda = (\text{width of finger})/(\text{spacing of fingers})$ appears as the parameter in a singly infinite set of such motions, all of which appear equally possible. Experiments in which various fluids were forced into a narrow Hele-Shaw cell showed that single fingers can be produced, and that unless the flow is very slow $\lambda = (\text{width of finger})/(\text{width of channel})$ is close to $\frac{1}{2}$, so that behind the tips of the advancing fingers the widths of the two columns of fluid are equal. When $\lambda = \frac{1}{2}$ the calculated form of the fingers is very close to that which is registered photographically in the Hele-Shaw cell, but at very slow speeds where the measured value of λ increased from $\frac{1}{2}$ to the limit 1.0 as the speed decreased to zero, there were considerable differences. Assuming that these might be due to surface tension, experiments were made in which a fluid of small viscosity, air or water, displaced a much more viscous oil. It is to be expected in that case that λ would be a function of $\mu U/T$ only, where μ is the viscosity, U the speed of advance and T the interfacial tension. This was verified using air as the less viscous fluid penetrating two oils of viscosities 0.30 and 4.5 poises.

1. THE STABILITY OF THE INTERFACE BETWEEN TWO FLUIDS IN A POROUS MEDIUM

It has been pointed out (Taylor 1950) and verified experimentally (Lewis 1950) that when two superposed fluids of different densities and negligible viscosities are accelerated in a direction perpendicular to their interface, this surface is stable or unstable for small deviations according as the acceleration is directed from the more dense to the less dense fluid or vice versa.

An analogous instability can occur when two superposed viscous fluids are forced by gravity and an imposed pressure gradient through a porous medium. If the steady state is one of uniform motion with velocity V vertically upwards and the

interface between the two fluids is horizontal, then it can be shown that the interface is stable for small deviations from the steady state if

$$\left(\frac{\mu_2}{k_2} - \frac{\mu_1}{k_1}\right) V + (\rho_2 - \rho_1) g > 0, \tag{1}$$

and unstable if
$$\left(\frac{\mu_2}{k_2} - \frac{\mu_1}{k_1}\right) V + (\rho_2 - \rho_1) g < 0, \tag{2}$$

where the suffix 1 refers to the upper fluid and the suffix 2 to the lower. The motion of the fluids through the medium is here supposed to be governed by Darcy's law which asserts that the velocity of the fluid is given by

$$\mathbf{u} = -\frac{k}{\mu} \text{grad} (p + \rho g x) = \text{grad } \phi, \quad \text{say,} \tag{3}$$

where \mathbf{u} denotes the velocity, μ the viscosity and ρ the density, k is the permeability of the medium to the fluid, g the acceleration due to gravity, x the vertical height above some horizontal plane, and ϕ is called the velocity potential.

To describe a disturbance of the surface of separation, take rectangular co-ordinates (x, y, z) , the instantaneous position of the undisturbed interface coinciding with the plane $x = 0$. Suppose the interface is deformed slightly into a wave-like corrugation of wavelength $2\pi/n$ described by

$$x = a e^{iny + \sigma t}. \tag{4}$$

Assuming that the fluids are incompressible and that the medium is of uniform porosity, the equation of continuity satisfied by the velocity field is $\text{div } \mathbf{u} = 0$ and the velocity potential therefore satisfies Laplace's equation $\nabla^2 \phi = 0$.

It is now necessary to make some assumption about the nature of the motion in the vicinity of the interface because, in fact, a sharp interface between the two fluids does not exist but there is, rather, an ill-defined transition region in which the two fluids intermingle. This region is often not very thick and we shall assume that the fluids do not interpenetrate to any marked extent and that the width of the transition zone is small compared with the length scale of the motion. It is then reasonable to assume for the purpose of mathematical analysis that the two fluids are separated by a sharp interface, across which the normal component of velocity and the pressure are continuous (surface tension or any other similar effect is neglected).†

It follows from the continuity of normal velocity that the velocity potentials in the upper and lower fluid satisfy on $x = 0$, to the first order in the deviation

$$\frac{\partial \phi_1}{\partial x} = \frac{\partial \phi_2}{\partial x} = V + a\sigma e^{iny + \sigma t}. \tag{5}$$

† The assumption that one fluid completely expels the other may sometimes be relaxed and the analysis can be modified to treat cases in which a proportion of one fluid is left behind to be surrounded by the oncoming fluid. The continuity of normal velocity across the interface no longer holds, but provided that the mixture of fluids can be regarded as homogeneous and the proportion left behind the interface is constant, then it is found that the interface moves as if it separated two fluids whose viscosities and densities differ from those of the original two fluids but which completely expel one another. The values of these viscosities and densities depend upon the physical properties of the mixture and the proportion left behind. In this connexion, see also the Appendix.

Hence,

$$\phi_1 = Vx - (a\sigma/n) e^{iny-nx+\sigma t}$$

and

$$\phi_2 = Vx + (a\sigma/n) e^{iny+nx+\sigma t},$$

these being the appropriate solutions of $\nabla^2\phi = 0$ which satisfy (5) and for which the disturbance vanishes at infinity.

The pressure, p_1 , in the upper fluid is $-(\mu_1/k_1)\phi_1 - \rho_1 gx$ and that, p_2 , in the lower fluid is $-(\mu_2/k_2)\phi_2 - \rho_2 gx$. Equating the values of p_1 and p_2 on the interface (4), we find that, to the first order in the deviation, σ must satisfy

$$\frac{\sigma}{n} \left(\frac{\mu_1}{k_1} + \frac{\mu_2}{k_2} \right) = (\rho_1 - \rho_2) g + \left(\frac{\mu_1}{k_1} - \frac{\mu_2}{k_2} \right) V. \quad (6)$$

If the right-hand side of (6) is positive, then σ is positive and the amplitude of the deviation increases at an exponential rate and the interface is then unstable to small disturbances. If the right-hand side is negative, the deviation is damped at an exponential rate and the motion is stable to small disturbances. Thus, the results (1) and (2) are true for all wavelengths and consequently for all types of small disturbance. They can also be put as follows. When two superposed fluids of different viscosities are forced through a porous medium in a direction perpendicular to their interface, this surface is stable or unstable to small deviations according as the direction of motion is directed from the more viscous to the less viscous fluid or vice versa, whatever the relative densities of the fluids, provided that the velocity is sufficiently large.

It appears that this result is not essentially new and that mining engineers and geologists have long been aware of it. In certain types of oil wells the oil taken out of the ground is replaced by encroaching water which comes from the expansion of a large water accumulation or seepage from the surface. Since oil is lighter than water but somewhat more viscous, it follows from (2) that when the velocity of extraction is too large the interface will become unstable. It is indeed observed in practice that when the velocity of extraction is too large, long tongues or cones of water penetrate the oil and it comes out of the well mixed with water. This phenomenon is known in the literature as 'water tonguing or coning'. However, earlier writers (e.g. Dietz 1953; Kidder 1956) do not appear to have considered explicitly the stability of the interface, but rather the conditions necessary in certain cases for a steady interface to exist.

2. AN ANALOGUE FOR TWO-DIMENSIONAL FLOW IN A POROUS MEDIUM

The motion of fluid in a porous medium according to Darcy's law can be derived from a potential $\phi = -(k/\mu)(p + \rho gx)$. Motion in two dimensions can therefore be studied experimentally by means of an analogue devised by Hele-Shaw (1898). This makes use of the result that the motion of a viscous fluid, between two fixed parallel plates which are sufficiently close together, is such that the components of the mean velocity across the stratum are

$$u = -\frac{b^2}{12\mu} \left(\frac{\partial p}{\partial x} + \rho g \right), \quad v = -\frac{b^2}{12\mu} \frac{\partial p}{\partial y}, \quad (7)$$

where b denotes the distance between the plates (see, for example, Lamb 1932, § 330). The plates are here taken as vertical, the x -axis is vertically upwards, the y -axis

parallel to the plates, and the z -axis perpendicular to the plates; u and v are the components of mean velocity in the x - and y -directions, respectively.

These are the equations satisfied by the velocity in a porous media of permeability $b^2/12$ and there is thus a direct analogy between two-dimensional flow in a porous medium and the flow between parallel plates, the velocity in the former case corresponding to the mean velocity in the latter. In this way, for example, the streamlines for the flow around bodies of arbitrary shape can be determined experimentally.

The analogue can also be used to reproduce experimentally the (two-dimensional) motion of the interface between two fluids in a porous medium. Consider the motion between parallel plates of two immiscible fluids of viscosities μ_1, μ_2 and densities ρ_1, ρ_2 , respectively, and suppose the direction of motion is away from fluid 2 towards fluid 1. Now the fluid 1 is not necessarily completely expelled or replaced by fluid 2, a film of fluid 1 may wet the plates and adhere to them, while a tongue of fluid 2 advances along the middle of the gap between the plates. The thickness of the tongue may be taken as a fraction t , say, of the gap between the plates and the analysis which follows is applicable and the analogue valid provided that t is constant.

In experiments to be described later, one of the fluids (fluid 2) was air and in order to find out what proportion of fluid 1 was left behind after the interface (or the tip of the meniscus) has passed, subsidiary experiments were made in which a measured volume of air was blown centrally into the narrow space (0.09 cm) between the flat base of a metal vessel containing oil or glycerine and a circular flat glass disk. The rather irregular outline of the bubble so formed was photographed and the area contained within it determined. In several such trials it was found that the volume of the bubble divided by the area gave a thickness which was always less than 0.09 cm but was never more than $1\frac{1}{2}\%$ less. The rate at which the air was blown into the apparatus had to be kept low for otherwise the instability which gives rise to the irregular outlines of the interface made it difficult to measure the area. The velocity of the interface was, however, of the same order as those occurring in the experiments to be described later. In discussing those experiments, it is therefore legitimate to assume that $t = 1$ and the outlines which were observed and photographed represent interfaces completely separating the two fluids.

The thickness of the film of liquid left behind when a bubble moves in a capillary tube has been investigated (Fairbrother & Stubbs 1935) and shown to depend on the non-dimensional parameter $\mu U/T$, where μ is the viscosity, U is the velocity of the bubble and T the surface tension. The value of the parameter in our experiments was such that only a small fraction of the fluid would be expected to remain behind.

The mean velocity across the stratum of fluid 1 ahead of the interface is given by (assuming b to be sufficiently small)

$$\mathbf{u}_1 = -(b^2/12\mu_1) \text{grad}(p + \rho_1 gx) = \text{grad } \phi_1, \quad \text{say}, \quad (8)$$

taking the plates vertical and the x -axis vertically upwards. Taking $t = 1$ and fluid 1 to be completely expelled, the mean velocity across the stratum of fluid 2 is given by

$$\mathbf{u}_2 = -(b^2/12\mu_2) \text{grad}(p + \rho_2 gx) = \text{grad } \phi_2, \quad \text{say}. \quad (9)$$

Now when b is small, the width of the projection of the meniscus on to the plates is small, and expressions (8) and (9) can be supposed to hold (for the purposes of the analysis) right up to the interface which may be regarded as a sharp line. It follows from continuity that the components of \mathbf{u}_1 and \mathbf{u}_2 normal to the interface are continuous across the interface; if surface tension effects are negligible the pressure is constant across the interface (see, further, § 5 below), and the motion of the two fluids will then reproduce the two-dimensional motion of the interface between two fluids of viscosities μ_1 and μ_2 in a porous medium of permeability $b^2/12$.

The analogue is still valid when $t \neq 1$, provided that t is constant. For this case, the interface can be identified with the tip of the meniscus between the two fluids. The modifications that are required are given in the Appendix.

The considerations of § 1 apply to the motion in the Hele-Shaw cell and it will be noticed that when the cell is vertical there is a critical velocity for the interface, which separates unstable from stable conditions. This is given by (1) and (2) with k_1 and k_2 replaced by $b^2/12$. When the Hele-Shaw apparatus is set horizontal the analysis applies with g put equal to zero, and it follows that the interface is always unstable when the less viscous fluid is driving the more viscous.

3. EFFECT OF SURFACE TENSION ON STABILITY IN THE HELE-SHAW CELL

The effect of surface tension on the stability of the interface may depend on a variety of physical conditions. The simplest assumption is to take the pressure drop through the interface as $T(2/b + 1/R)$, where R is the radius of curvature of the projection on the planes bounding the cell of the tip of the meniscus. In discussing the stability of a plane interface in the Hele-Shaw apparatus, this may be taken as $T(2/b + d^2x/dy^2)$, where x is given by (4), and it is easily seen that (6) is thereby altered to

$$\frac{12}{b^2} \sigma(\mu_1 + \mu_2) = \frac{2\pi}{l} \left\{ \frac{12V}{b^2} (\mu_1 - \mu_2) + g(\rho_1 - \rho_2) \right\} - \frac{8\pi^3 T}{l^3}, \quad (10)$$

where σ is the amplification factor of disturbances of wavelength $l = 2\pi/n$.

It will be seen that this effect of surface tension is to limit the range of disturbances which are unstable to those of wavelength greater than

$$l_{\text{crit.}} = 2\pi T^{1/3} b \{ 12V(\mu_1 - \mu_2) + b^2 g(\rho_1 - \rho_2) \}^{-1/3}. \quad (11)$$

That surface tension should have this effect was pointed out to us by Dr Chuoke in a similar connexion, the amplification factor is a maximum for disturbances of wavelength $\sqrt{3} l_{\text{crit.}}$

4. EXPERIMENTS USING THE HELE-SHAW CELL

It was shown experimentally (Lewis 1950) that the unstable accelerating interface between two fluids of different density develops in such a way that long fingers of the less dense fluid penetrate into the more dense one, and beyond the level to which these fingers have penetrated into the more dense fluid the acceleration has the same value it would have if the interface had remained plane. Analogous results are obtained when the Hele-Shaw apparatus contains two immiscible fluids.

In the first apparatus, two pieces of commercially flat plate glass were separated by strips of rubber 0.09 cm thick laid long their long edges. The channel $0.09 \times 12 \times 38$ cm thus formed was connected at its two ends with vessels containing the two fluids. The pressure gradient along the channel was produced by applying air pressure or suction to the airspace above the fluid in one of the end vessels and the pressure at the other was maintained at that of the atmosphere. The apparatus which is shown in the sketch (figure 1) could be used either vertically or horizontally and the meniscus of the interface could be photographed as a sharp line. The three-cock shown in figure 1 on the left side of the top of the front view made it possible

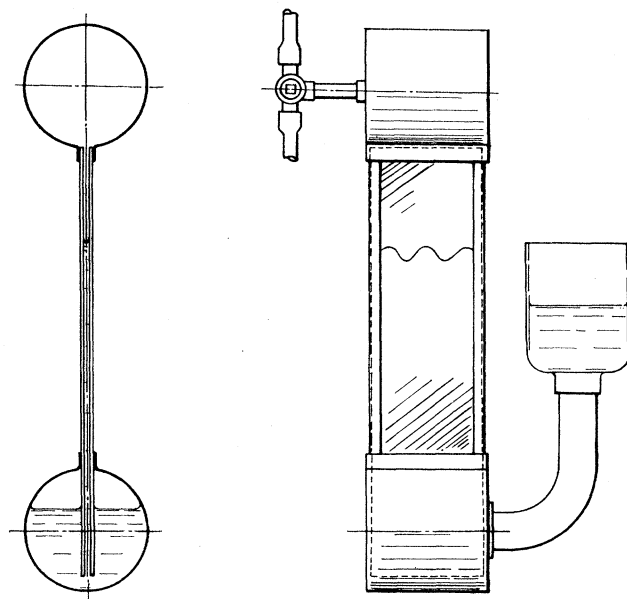

FIGURE 1. Sketch of Hele-Shaw cell.

to change the pressure in the air chamber rapidly from pressure to suction. The first experiments were made with the apparatus vertical and with glycerine as the more viscous and air as the less viscous fluid. In this case the critical velocity is downwards and the unstable disturbances are to be expected when the air is above if the velocity is downwards and greater than this. If the glycerine lies above the air the flow becomes stable when the downwards velocity is greater than the critical.

In the experiment shown in figure 2, plate 2, the fluid was sucked up to near the top of the Hele-Shaw channel and allowed to fall with a velocity less than the critical and then maintained at rest for a short time. The fluid left behind on the glass then gathered itself together to form vertical streaks which produced on the interface a small variation in level. The air pressure was then turned on; this is indicated by the mercury manometer seen to the left of the channel. The photograph was taken by a flash bulb after the glycerine had been forced downwards through a few centimetres. It will be seen that the instability has already manifested itself. In

this experiment V was 0.1 cm/s and the critical wavelength given by (11) was 1.2 cm; the average wavelength of the disturbance shown in figure 2 was 2.2 cm, so that instability was to be expected.

Figure 3, plate 2, shows a later stage of the instability (not in the same experiment as that of figure 2). In this case the pressure was turned on when the nearly straight interface was at the level of the top of the mark seen projecting from the left-hand side of the channel. A characteristic feature of the later stages of the growth of 'instability' into 'fingers', is shown in figure 3, namely the tendency of the fingers to space themselves so that the width of the air fingers and the columns of fluid between them are of approximately the same breadth. The development of these fingers is very similar to those recorded by Lewis for the later states of instability of an accelerated interface, but it differs from them in that the air fingers in Lewis's experiment were separated by very narrow columns of fluid.

The reason for the narrow columns in Lewis's experiment was that the water left behind after the passage of the front of 'fingers' is in a field of uniform pressure, and therefore moves uniformly at the speed at which it was passed by the front, while the fluid ahead of this front is accelerating away from it. There is thus a longitudinal rate of strain in the columns so that they must continually decrease in thickness as the front leaves them.

Figure 4, plate 2, shows another characteristic feature, the inhibiting effect on the growth of its neighbours that happens when the end of one of the fingers gets ahead of them. On the right-hand side of this photograph can be seen three fingers which started to grow at the same time. The middle finger, however, was slightly larger than its neighbours and at the stage shown in figure 4 has almost completely inhibited their growth and as it passed them it spread laterally. The inhibiting effect on the growth of neighbours by any finger which gets ahead of them also occurred in Lewis's experiments and was due to the same cause.

In attempting to form a mathematical description of the mechanics of the formation of 'fingers' we were naturally led to consider an infinite set of equal and equally spaced fingers all advancing at the same speed. Since each finger is then identical mathematically with all the others and the fluid on the straight lines halfway between neighbours has no transverse component of velocity, we considered only a single finger propagating itself in a channel of fixed width. The details of the analysis will be given in the next section.

DESCRIPTION OF PLATE 2

FIGURE 2. Interface between air and glycerine at an early stage of the instability.

FIGURE 3. Development of instability.

FIGURE 4. Inhibiting effect of a finger which gets ahead of its neighbour.

FIGURE 8. An air finger advancing into glycerine.

FIGURE 9. Enlarged forward portion of the finger shown in figure 8. \circ , points calculated from (17) using $\lambda = \frac{1}{2}$.

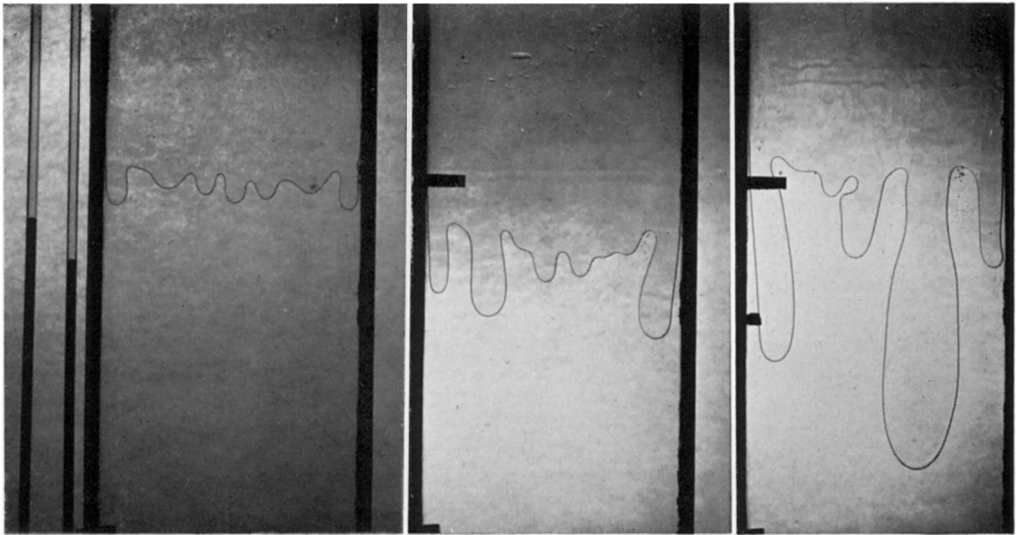

FIGURE 2

FIGURE 3

FIGURE 4

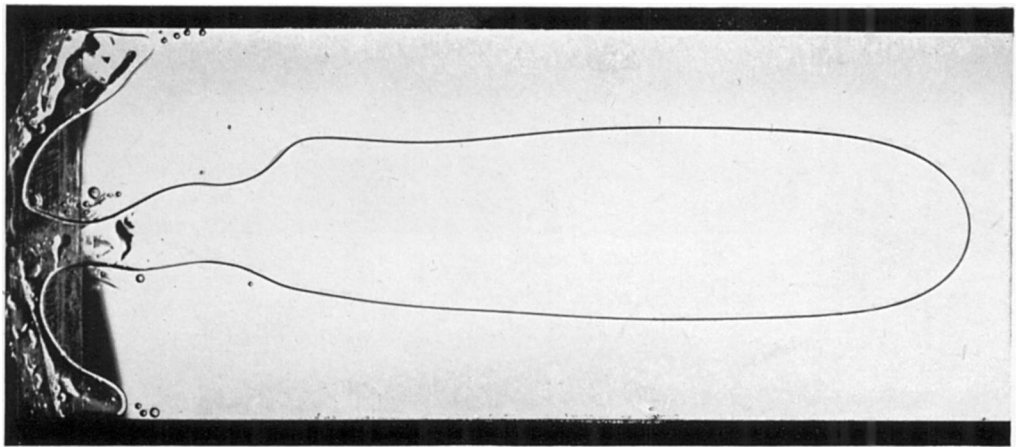

FIGURE 8

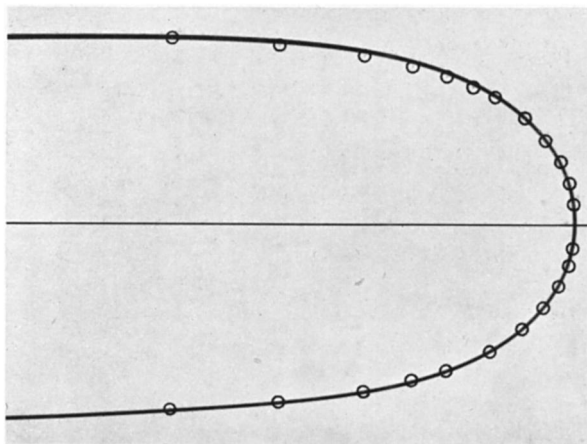

FIGURE 9

(Facing p. 318)

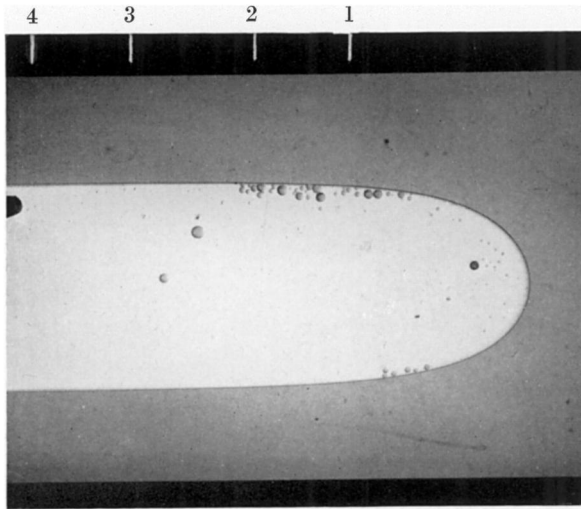

FIGURE 11. Finger of oil ($\mu = 4.5$ P) penetrating glycerine ($\mu = 9$ P).

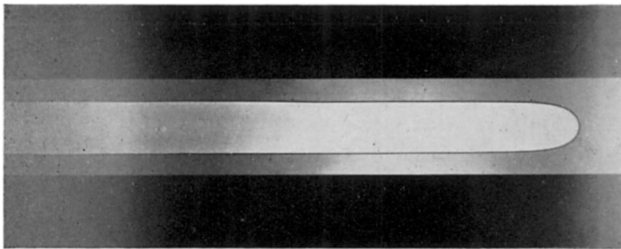

FIGURE 12. Finger of water penetrating oil (Shell Diala).

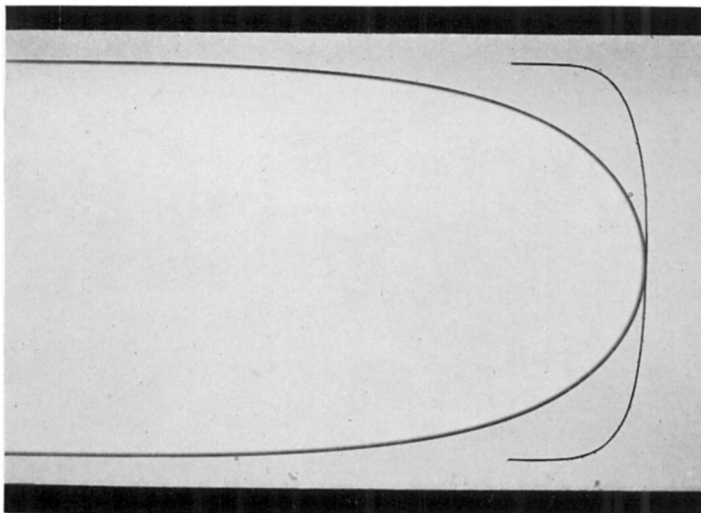

FIGURE 13. Water penetrating into oil at slow speed. Profile calculated from (17) for $\lambda = 0.87$ superposed.

5. PENETRATION OF A SINGLE 'FINGER' INTO A CHANNEL

In this section we consider the analysis of the motion of a long bubble or 'finger' of fluid moving through an infinite channel in the Hele-Shaw cell filled with a viscous fluid and bounded by straight parallel walls. As described in the previous section, the motion of these bubbles is connected with the mechanics of the formation and propagation of 'fingers' and, by virtue of the analogue, also bears on the question of how long it would take for a vertical tube or channel of saturated porous material to drain when closed at the top and open at the bottom. The analogous problem for inviscid liquids of the motion of bubbles through liquids in tubes and channels has been studied experimentally and theoretically in some detail (see, for example, Davies & Taylor 1950; Garabedian 1957). The present problem is of particular interest, since it is possible to obtain exact solutions of the equations of motion in closed form and compare them with experiment.

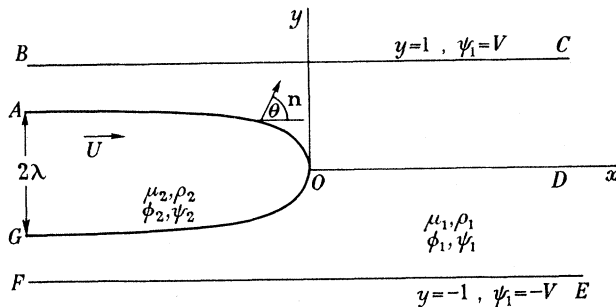

FIGURE 5. Finger moving into a channel.

A bubble of fluid of viscosity μ_2 and density ρ_2 is supposed to be moving steadily through a vertical channel in the Hele-Shaw cell filled with fluid of viscosity μ_1 and density ρ_1 . In figures 5, BC and FE are the walls of the channel, AOG is the surface of the bubble or interface between the two fluids, the x -axis is taken vertically upwards along the centre of the channel, the y -axis horizontal and perpendicular to the walls, and the origin is at the nose of the bubble which is supposed to be of infinite extent and symmetrical about the centre of the channel. The velocity of the bubble is denoted by U and the velocity of the fluid at infinity in front of the bubble by V . The walls of the channel are taken as $y = \pm 1$, and the width of the bubble at infinity as 2λ , where λ is a parameter which is for the present unspecified except that it lies between 0 and 1. Suffices 1 and 2 refer to quantities outside and inside the bubble, respectively.

The mean velocity across the stratum is given by equations (8) and (9) and the equation of continuity takes the form

$$\frac{\partial u}{\partial x} + \frac{\partial v}{\partial y} = 0,$$

where u and v are the components of mean velocity parallel to the axes. A stream function ψ can be defined by

$$u = \frac{\partial \phi}{\partial x} = \frac{\partial \psi}{\partial y}, \quad v = \frac{\partial \phi}{\partial y} = -\frac{\partial \psi}{\partial x},$$

and it follows from the Cauchy–Riemann equations that $w = \phi + i\psi$ is an analytic function of $z = x + iy$.

It will be assumed that the experiment described in §2 is valid, i.e. one fluid completely expels the other, and that the meniscus separating the two fluids is a sharp line, so that the components of mean velocity normal to the interface are continuous, i.e.

$$\frac{\partial\phi_1}{\partial n} = \frac{\partial\phi_2}{\partial n} = U \cos \theta, \quad (12)$$

where θ is the angle between the x -axis and the outward normal \mathbf{n} to the interface. Now $\partial\phi/\partial n = \partial\psi/\partial s$ where $\partial/\partial s$ denotes differentiation along the interface, and $\cos \theta = \partial y/\partial s$, from which it follows that

$$\psi_1 = \psi_2 = Uy \quad (13)$$

on the surface of the bubble.

If the pressure change due to surface tension at the interface is ignored, the equation for continuity of pressure is

$$(12/b^2)(\mu_1\phi_1 - \mu_2\phi_2) = g(\rho_2 - \rho_1)x. \quad (14)$$

The same equation is valid if the change in pressure on passing through the interface is constant, since an arbitrary constant may be added to the velocity potential. If the fluid wets the plane surfaces it might be expected that under static conditions the pressure drop would be $T(2/b + 1/R)$, where R is the radius of curvature of the meniscus on the plane of the two parallel sheets which bound the cell. The assumption that this is constant amounts to neglecting $1/R$ in comparison with $2/b$ and to assuming that the surface tension and curvature of the interface are identical with their static values. The range of validity of equation (14) will be discussed later.

The remaining conditions on the velocity potentials and stream functions are $\phi_1 \sim Vx$ as $x \rightarrow +\infty$, $\phi_2 \sim Ux$ as $x \rightarrow -\infty$, and $\psi_1 = \pm V$ on $y = \pm 1$, since the walls of the channel must be streamlines. (We neglect the edge effects which occur at solid boundaries in the Hele-Shaw cell and invalidate the equations of motion (8) and (9) within a distance of order b from these boundaries.)

We examine first the case in which the fluid inside the bubble is of negligible viscosity and density, and suppose also that gravity forces are negligible, i.e. that the imposed pressure gradient which moves the fluid is large compared with that due to gravity. This case corresponds to the experimental arrangement described in §7 below when a bubble of air is blown through glycerine.

Equation (14) now reduces to $\phi_1 = 0$ on the bubble surface. Further, the flow becomes uniform a long way behind the nose of the bubble, i.e. as $x \rightarrow -\infty$, and since ϕ_1 is zero on the interface, $\phi_1 \rightarrow 0$ as $x \rightarrow -\infty$ and the fluid is at rest at $x = -\infty$. Hence, the stream function has the same value at A as at B (and also at G as at F) and it follows from (13) that

$$V = \lambda U. \quad (15)$$

Equation (15) gives the velocity of the bubble in terms of its width and the velocity at infinity; the latter velocity will be determined by the external means by which the motion is generated.

The shape of the interface is as yet unknown and to solve this free boundary problem, we transform into the ϕ, ψ plane and consider $x + iy$ as an analytic function of $\phi + i\psi$ (for brevity we drop the suffix 1).† In figure 6, corresponding points in the physical and potential planes are marked with the same letter; the exterior of the bubble transforms into the semi-infinite strip $\phi > 0, -V < \psi < V$, the surface of the bubble to the ϕ axis between $\psi = \pm V$, and the walls of the channel to $\psi = \pm V$.

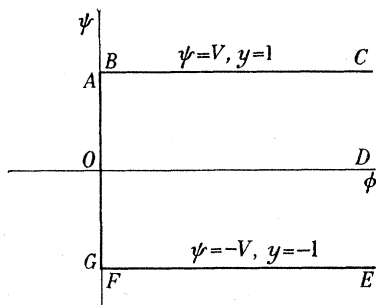

FIGURE 6. The potential plane for motion in a channel.

Now y is a harmonic function of ϕ and ψ which has the values -1 on FE , 0 on DO , $+1$ on BC , $y = \psi/U$ on GA (the surface of the bubble), and $y \rightarrow \psi/V$ as $\phi \rightarrow +\infty$.

Take, therefore,

$$y = \frac{\psi}{V} + \sum_1^{\infty} A_n \sin \frac{n\pi\psi}{V} \exp\left(-\frac{n\pi\phi}{V}\right).$$

This is a harmonic function satisfying all the boundary conditions, provided

$$\frac{\psi}{U} = \frac{\psi}{V} + \sum_1^{\infty} A_n \sin \frac{n\pi\psi}{V}, \quad \text{for } -V < \psi < V.$$

Calculating the coefficients by the usual method of Fourier series, we find that

$$A_n = -\frac{2}{\pi} \left(1 - \frac{V}{U}\right) = -\frac{2}{\pi} (1 - \lambda),$$

and therefore

$$z = \frac{w}{V} + \frac{2}{\pi} (1 - \lambda) \ln \frac{1}{2} \left(1 + \exp\left[-\frac{\pi w}{V}\right]\right). \tag{16}$$

This equation determines the complex potential implicitly as a function of z . The pressure then follows from the relation

$$p = -\frac{b^2}{12\mu} \phi + \text{const.}$$

The parametric equation of the interface is obtained by putting $\phi = 0$ in equation (16) and it follows that the bubble surface is

$$x = \frac{1 - \lambda}{\pi} \ln \frac{1}{2} \left(1 + \cos \frac{\pi y}{\lambda}\right). \tag{17}$$

This completes the solution for the case of a bubble of fluid of negligible viscosity when effects due to gravity forces and departures from equation (14) are unimportant.

† We are grateful to Mr F. Ursell for first suggesting this transformation to us.

Before discussing this further, we give briefly the solution for the more general case in which the viscosity of the fluid in the bubble is not neglected and pressure gradients due to gravity are taken into account. The equations of motion for the fluid inside the bubble can be satisfied by taking

$$\phi_2 + i\psi_2 = U(x + iy). \quad (18)$$

The boundary condition for ϕ_1 then becomes $\phi_1 = -U^*x$ on the bubble, where

$$\frac{12\mu_1 U^*}{b^2} = g(\rho_1 - \rho_2) - \frac{12\mu_2 U}{b^2}. \quad (19)$$

Define now

$$W = \Phi + i\Psi = w_1 + U^*z. \quad (20)$$

On the interface, $\Phi = 0$, $\Psi = (U + U^*)y$; further $\Psi = \pm(V + U^*)$ on $y = \pm 1$ and $W \rightarrow (V + U^*)z$ as $x \rightarrow +\infty$. The problem is thus reduced to the simpler case considered above and the complex potential for the motion outside the bubble is given by (15) and (16) with V replaced by $V + U^*$, U by $U + U^*$, and w by W . The bubble surface corresponds to $\Phi = 0$ and is therefore given by (17) also. It is worth noticing that if the asymptotic width at infinity is fixed, then the shape of the bubble is independent of the physical properties of the fluids. The width 2λ of the bubble is given in terms of U (the velocity of the bubble), V (the velocity at infinity), and the physical properties of the fluids by

$$\lambda = \frac{V + U^*}{U + U^*}.$$

The maximum velocity of propagation again corresponds to $\lambda = 0$ and is

$$U_{\max.} = \frac{\mu_1}{\mu_2} V + \frac{b^2 g}{12\mu_2} (\rho_1 - \rho_2).$$

6. NON-UNIQUENESS OF THE SOLUTION

There is nothing in the preceding mathematical analysis to determine the width of the bubble and the value of λ , i.e. the fraction of the channel occupied by the bubble after the nose has passed. In other words, if only the velocity at infinity ahead of the bubble is specified (this is equivalent to specifying the pressures driving the less viscous finger into the more viscous fluid), then the free-boundary problem does not have a unique solution and there are an infinite number of possible steady shapes, each with a different velocity of propagation. These shapes are the members of the family of curves given by (17) for values of λ between 0 and 1. The velocity of propagation of the bubble corresponding to each of these shapes is related to the velocity at infinity by (15). The two extreme members are given by $\lambda = 1$ when the interface extends in a straight line across the whole width of the channel, and $\lambda = 0$ when the bubble has zero width and propagates with infinite velocity. The calculated shapes for $\lambda = 0.2, 0.5$ and 0.8 are shown in figure 7.

It was pointed out recently by Garabedian (1957) that the analogous free-boundary problem for the propagation of an air bubble through a vertical tube or channel containing an inviscid liquid also does not possess a unique solution, and

that there are many possible 'equilibrium' shapes which a bubble can have, each again corresponding to a different velocity of rise. (Garabedian did not demonstrate explicitly the multiplicity of solutions and it is of some interest that this can be done for the problem we are considering.) He gave arguments based on the hypothesis of a maximum rate of loss of potential energy to show that in practice only one of these possible shapes would occur, the one occurring being that with the maximum velocity of propagation.

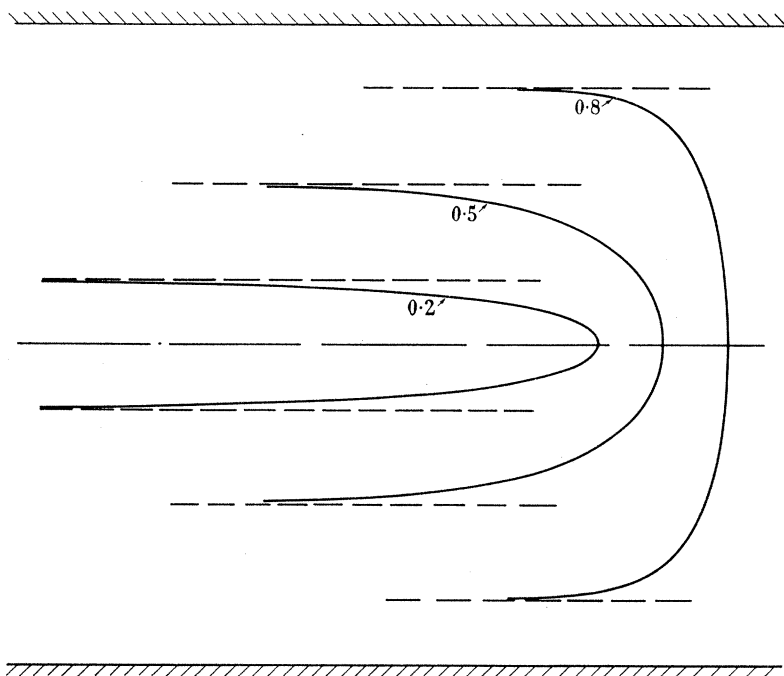

FIGURE 7. Calculated profiles for $\lambda = 0.2$, 0.5 and 0.8 .

These arguments do not apply to motion in a porous medium or a Hele-Shaw cell, since the motion is then dissipative and in any case the maximum velocity of propagation according to the analysis is infinite, but we should still expect on the grounds of physical experience that only one of all the possible shapes would occur in practice. It should be noted that the hypothesis of a maximum or minimum rate of dissipation of energy by viscosity does not determine a unique value for λ , since this rate for a channel of finite, but very large length is proportional to the product of the velocity at infinity and the pressure difference between the ends of the channel, and it follows from (16) that the value of this product becomes independent of λ as the length of the channel tends to infinity. (The terms involving λ , which tend to zero as the length increases, are monotonic in λ and a hypothesis of maximum or minimum dissipation would in any case give $\lambda = 1$ or $\lambda = 0$.)

Our experiments with the Hele-Shaw cell indicate that, as the speed of flow for any given fluid increases, λ rapidly decreases to $\lambda = \frac{1}{2}$ and remains close to this value over a large range of speeds, till at high speeds of flow the tongue or finger of the advancing fluid itself breaks down and divides into smaller fingers.

7. EXPERIMENTS IN CHANNELS

The apparatus with which the photographs of figures 2 to 4 were taken was not suitable for producing single steadily moving bubbles of the type considered in the analysis. It was not long enough to permit one of the fingers to grow at the expense of the others and thus be propagated as a single steadily moving column. The apparatus was therefore modified by inserting liners between the plates which limited the width of the viscous fluid channel to 5.6 cm, leaving the length (38 cm) and thickness (0.09 cm) unchanged, and it was used horizontally. With this width it was possible to obtain bubbles which for several inches behind the advancing meniscus were parallel sided. Figure 8, plate, 2 is a photograph of one. It will be seen that the 'finger' starting from an artificial initial disturbance, produced by blowing a small central air bubble close to the initially straight meniscus, swells out to a definite breadth and is then propagated without further change down the channel. The outer edge of the outline of the bubble represents the outer edge of the meniscus and, measuring the breadth of this at its widest section on the enlarged photograph of figure 8, it was found to be 5.10 cm. The two liners which limit the breadth of the channel appear black in figure 8 and the width between them measured on this photograph with a reading microscope was 10.29 cm, so that

$$\lambda = \frac{5.10}{10.29} = 0.496.$$

In several experiments, λ was found to be within 2% of 0.50.

To compare the shape of the bubble with the results of calculation, the photograph was enlarged till the distance between the walls was 20.0 cm and the points calculated from expression (17) for the case when $\lambda = 0.50$ were pricked through transparent squared paper laid on the photograph. Small ink circles were then centred on these pinholes and the result reproduced in figure 9. It will be seen that the bubble profile agrees very well with the calculation when λ is taken as 0.50.

8. EXPERIMENTS WITH PAIRS OF VISCOUS FLUIDS

In the experiments so far described, air was used to drive out glycerine. The viscosity of air is only 1/50 000th of that of glycerine, but according to our calculations the same kind of instability would occur whatever the viscosity of the driving fluid, provided it is less than that of the fluid it is displacing. On the other hand, since we have no clue on theoretical grounds as to what determines the value of λ which will occur, it seemed possible that it might depend on the ratio of the viscosities, μ_2/μ_1 . For this reason experiments were made in which a shell oil mixture of viscosity 2.75 P was used to drive coloured glycerine of viscosity 8 P through our channel. It was found that when the two viscosities are comparable the length of run required before the driving fluid penetrates into the more viscous fluid in the form of a steadily moving 'finger' was much greater than when one is air. For this reason, a new channel was built of Perspex $2.54 \times 91 \times 0.08$ cm. This is shown in figure 10. The camera *A* points vertically downwards at the channel *B* which is illuminated by a flash-bulb *D* placed under a tracing-paper screen *C*. The driving pressure was produced by raising a water vessel *K* so as to increase the air pressure

in the bottle *J*. This raised the pressure above the fluid contained in the upstream reservoir *L*. The more viscous fluid was supplied from a vessel *F*, so as to fill the upstream reservoir *E*. If the pressure in *E* were maintained constant, as it would be if the pipe connecting *E* and *F* were left open, the velocity of the finger would increase as the length of the column of more viscous fluid decreased. To maintain a more constant velocity the cock *G* between *E* and *F* was closed during an experiment and the fluid in *E* escaped to the atmosphere through a needle valve *H*, the resistance of which was greater than that of the channel itself. By measuring the velocity of the head of the advancing finger before and after passing under the camera *A*, it was possible to obtain a good estimate of the velocity at the moment the photograph was taken.

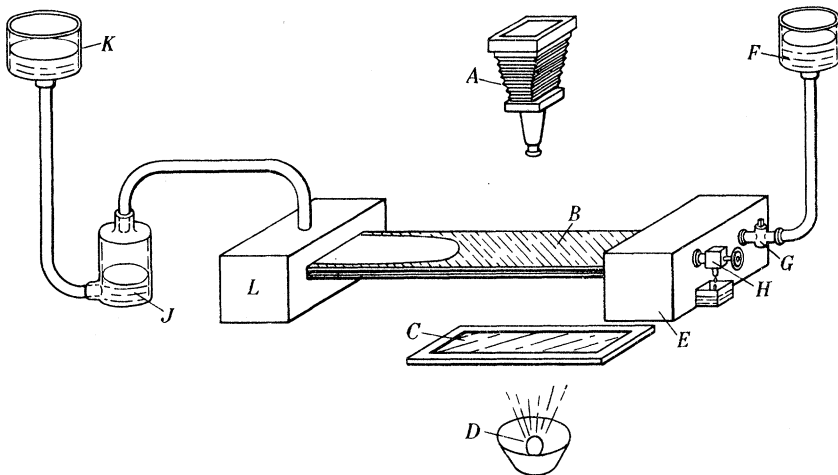

FIGURE 10. Arrangement of long Hele-Shaw cell for photographing fingers.

Figure 11, plate 3, shows a 'finger' of the oil penetrating at 1 mm/s into the tinted glycerine. It will be seen that the outline is very similar to that obtained with air and glycerine. Measurements of $\lambda = (\text{width of finger})/(\text{width of channel})$ were made at four sections which are marked on the photograph. These gave the following results:

position	1	2	3	4
λ	0.485	0.502	0.508	0.514

It will be seen that after running a distance of 70 cm, i.e. 28 times the width of the channel, the finger has nearly, but not quite, settled down to a constant width of a little more than half the width of the channel.

Figure 12, plate 3, covers a larger part of the channel and shows water penetrating into oil in the form of a very uniform finger.

9. EFFECT ON THE SHAPE OF THE BUBBLE OF SURFACE STRESS AT THE INTERFACE

The good agreement between the photograph of the bubble shape (figure 9) and that calculated for the case when $\lambda = \frac{1}{2}$ is an indication that the boundary condition (14), which expresses the assumption that the pressure difference between the two

sides of the interface is constant over its length, is justifiable at the flow speed used. When experiments were made at much lower speeds, however, it was found that the bubble was wider but that the wider forms do not conform to the corresponding profiles calculated for the same value of λ from equation (17). Figure 13, plate 3, for instance, shows water penetrating into an oil (Shell Diala) at a speed 0.226 cm/s in the channel of dimensions $0.08 \times 2.54 \times 91$ cm. The value of λ obtained by measuring this photograph is 0.87. The contour for $\lambda = 0.87$ calculated using (17) is shown superposed on the photograph. The calculated contour is one along which the pressure in the fluid is constant. The fact that the observed contour is less flat than the calculated curve indicates intuitively that the pressure in the fluid increases on passing along it from the vertex. (It is hoped later to investigate quantitatively the actual pressure distribution and verify this directly.) Since the pressure inside the finger must be nearly constant along the contour, this means that the pressure difference which is supported by the interface must decrease on passing from the vertex towards the parallel portion. This pressure difference can only be attributed to surface tension or some equivalent surface stress. Under that general heading, however, various physical effects might be distinguished.

If, for instance, they are due to a constant surface tension of a fluid which wets the walls of the channel and leaves only a negligible amount of the penetrated fluid behind after the interface has passed, one would naturally look to the curvature of the meniscus in the plane midway between the parallel sheets. If, on the other hand, the interface has a finite angle of contact it might be necessary to study how that angle of contact varies when the interface moves over the plane surface. Possible differences between surface tension measured statically and that which acts over newly formed surfaces should also be studied. These things involve further experimental work, some of which is now being carried out at the Cavendish Laboratory, and it may be some time before the results are available. In the present note we propose to discuss only those which afford justification for the use of the boundary condition (14) in the theoretical discussion.

Confining attention to the case when a viscous fluid of interfacial tension T is driven slowly by a fluid of much smaller viscosity such as water or air, it is to be expected on dimensional grounds that the shape of the meniscus in a channel of given shape should be a function of $\mu U/T$ only, when the shape of the channel is fixed and the fluid wets the flat slides of the channel. It was found that neither water nor glycerine wet the Perspex which was used to construct the channel; accordingly two oils of very different viscosities, which have in static experiments nearly the same interfacial tension, were used to test whether λ is a function of $\mu U/T$ only.

The two oils used were Shell Diala ($\mu = 0.30$ P, $\rho = 0.875$ g/cm³) and Shell Talpa ($\mu = 4.5$ P, $\rho = 0.90$ g/cm³), and measurements were made using both water and air as the less viscous fluid. The viscosities were determined by measuring the flow through a Veridia accurate bore tube of 1.0 mm bore at 20 °C. To measure the interfacial tension between these oils and air a tube of 0.5 mm bore was dipped into the oil and the height to which the meniscus rose was observed. The surface tension of Diala was found to be between 27 and 30 dyn/cm at 20 °C, and that of Talpa slightly higher. The interfacial tension between the oils and water was measured

by two methods. In the first a vertical short length of 0.5 mm tube was lowered through a thick layer of oil lying above water, till the upper end was submerged in the oil and the lower end penetrated into the water. The oil wetted the tube and a meniscus convex upwards was formed in the tube. The depth of this below the level of the oil/water interface was measured. The high viscosities of the oils and the comparatively small difference in density of the oil and water made the meniscus move slowly, but consistent results were obtained even with the more viscous oil when an hour or so was allowed to elapse between inserting the tube and measuring the height of the interface.

In this way interfacial tensions between 13.5 and 15 dyn/cm were measured for the Diala/water interface. The other method was to insert a longer piece of $\frac{1}{2}$ mm tube through the oil into the water. There were then two interfaces in the tube: an oil/air interface concave upwards and an oil/water interface downwards. The positions of these in relation to the levels of the flat oil and water surfaces outside the tube were measured. Knowing the densities of oil and water, and assuming that the oil wets the glass as it appeared to do, we obtain with this method the difference between the surface tensions at the two interfaces. Independent measurements gave the surface tension at the oil/air interface. This second method gave values for the interfacial tensions of Diala/water and Talpa/water of between 14 and 16.5.

The results of the experiments with water are shown in figure 14 in which the measured values of $\lambda = (\text{width of finger})/(\text{width of channel})$ are plotted as ordinates and $\mu U/T$ as abscissae. It will be seen that in spite of a 15 : 1 ratio in the viscosities the points obtained with the two oils appear to fall nearly on the same curve. Some of the points were obtained by direct measurement after the finger had been formed for some time while others were obtained by measuring the photographs. It will be noticed that the direct measurement points, particularly for the larger values of $\mu U/T$, correspond with rather smaller values of λ than those derived photographically. This seems to be because at the higher values of $\mu U/T$ a small amount of the fluid is left behind after the passage of the air finger, and this fluid then flows slowly outwards towards the sides of the channel thus slightly reducing the width of the air finger.

The most interesting feature of the results exhibited in figure 14, and of similar sets of observations using air instead of water as the finger, or using oil penetrating into glycerine, is that in all cases the value of λ rapidly decreases as $\mu U/T$ increases till it reaches a value which is very close to $\frac{1}{2}$. We have never measured values of λ appreciably less than $\frac{1}{2}$.

As $\mu U/T$ increases, the effect of surface tension in determining the shape of the interface decreases relatively to that of viscous stress. The fact that λ tends rapidly to $\frac{1}{2}$ as $\mu U/T$ increases, is an indication that when the physical conditions are such that the boundary condition (14) can legitimately be used, the only one of the set of shapes described by (17) which can actually occur is that for which $\lambda = \frac{1}{2}$. The probability that this conclusion is correct is strengthened by the very close agreement between the shape of the contour shown in the photograph of figure 9 with that calculated using $\lambda = \frac{1}{2}$ in (17).

We have found no theoretical reason for this deduction from observation, but we have noticed a few purely analytical features which distinguish the particular shape corresponding with $\lambda = \frac{1}{2}$ from those corresponding with other values of λ . These have been omitted from the present paper owing to lack of any obvious physical meaning.

It is perhaps worth mentioning, in conclusion, that we have investigated theoretically the stability for infinitesimal disturbance of the shapes given by (17) for the case in which the fluid inside the bubble is of negligible viscosity. The not entirely unexpected result was found that if surface tension effects are neglected, i.e. if the velocity potential is taken as constant along the perturbed surface, then all the shapes are unstable, whatever the value of λ . The analysis gives no indication about why the shape with $\lambda = \frac{1}{2}$ is observed in practice.

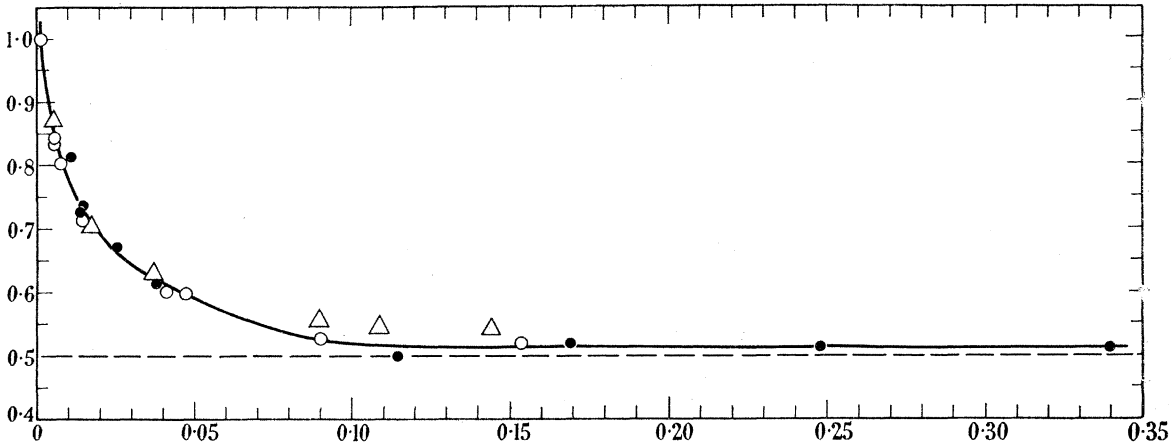

FIGURE 14. Measured values of λ for water penetrating into two oils: Δ , Diala (photographic measurements); \circ , Diala (direct measurement); \bullet , Talpa (direct measurements).

APPENDIX

In this appendix we give for completeness the modifications of the analysis of § 2 which are required when the penetrating fluid (fluid 2) does not completely expel the other (fluid 1), but a tongue of fluid 2, occupying a constant fraction t of the stratum between the plates bounding the Hele-Shaw cell, advances along the gap. It is assumed that the gap is small so that the mean velocity may be calculated by assuming that the motion is everywhere parallel to the plates, and that derivatives of the velocity in directions other than normal to the plates can be neglected in comparison with those along the normal. Using the co-ordinate system introduced in § 2, the mean velocity in fluid 1 ahead of the tongue is

$$\mathbf{u}_1 = -\frac{b^2}{12\mu_1} \text{grad} (p + \rho_1 g x). \tag{A 1}$$

After the passage of the tongue, the mean velocity of fluid 2 is

$$\mathbf{u}_2 = -\frac{b^2}{12\mu_2} \left(t^2 + \frac{3\mu_2}{2\mu_1} (1-t^2) \right) \text{grad} (p + \rho_2' g x), \tag{A 2}$$

where

$$\rho_2' = \rho_2 \left[1 + \frac{3\mu_2(1-t)^2 (\rho_1 - \rho_2)}{\rho_1 \{ 2\mu_1 t^2 + 3\mu_2(1-t^2) \}} \right]. \tag{A 3}$$

The mean velocity of the film of fluid 1 left adhering to the plates is

$$\mathbf{u}_{12} = -\frac{b^2}{12\mu_1} (1-t)(1+\frac{1}{2}t) \text{grad}(p + \rho_1 gx) - \frac{b^2 t(1-t)}{8\mu_1} \text{grad}(\rho_2 - \rho_1) gx. \quad (\text{A } 4)$$

The interface is taken as the tip of the meniscus, which advances with velocity $U = \mathbf{n} \cdot \mathbf{u}_2$ normal to itself, where \mathbf{n} is the outwards normal to the projection of the tip of the meniscus on the plates. The equation of continuity across the interface is

$$\mathbf{n} \cdot \mathbf{u}_1 = t\mathbf{n} \cdot \mathbf{u}_2 + (1-t)\mathbf{n} \cdot \mathbf{u}_{12}. \quad (\text{A } 5)$$

If we define \mathbf{u}'_1 by

$$\mathbf{u}'_1 = -\frac{b^2}{12\mu_1 A} \text{grad}(p + \rho_1(1+B)gx), \quad (\text{A } 6)$$

where

$$A = t + \frac{\mu_2(1-t)^2(1+\frac{1}{2}t)}{\mu_1 t + \frac{3}{2}\mu_2(1-t^2)}, \quad B = (1-t)^2 \left\{ \left(1 + \frac{1}{2}t\right) \left(\frac{\rho'_2}{\rho_1} - 1\right) - \frac{3}{2}t \left(\frac{\rho_2}{\rho_1} - 1\right) \right\},$$

then it can be shown that

$$U = \mathbf{n} \cdot \mathbf{u}'_1,$$

at the interface.

Hence, the motion of the interface in the case in which a constant fraction t of fluid 2 penetrates fluid 1 corresponds, according to the analysis, with the motion of the interface between a fluid of viscosity μ_2 and density ρ'_2 , which completely expels a fluid of viscosity $A\mu_1$ and density $\rho_1(1+B)$. Thus, the kinematics of the motion are unaltered by a constant fraction of the penetrated fluid being left adhering to the plates bounding the cell.

REFERENCES

- Davies, R. M. & Taylor, Sir Geoffrey 1950 *Proc. Roy. Soc. A*, **200**, 375.
 Dietz, D. N. 1953 *Proc. Acad. Sci. Amst. B*, **56**, 83.
 Fairbrother, F. & Stubbs, A. E. 1935 *J. Chem. Soc.* p. 527.
 Garabedian, P. R. 1957 *Proc. Roy. Soc. A*, **241**, 423.
 Hele-Shaw, H. S. S. 1898 *Trans. Instn Nav. Archit., Lond.*, **40**, 21.
 Kidder, R. E. 1956 *J. Appl. Phys.* **27**, 867.
 Lamb, H. 1932 *Hydrodynamics*, 6th ed. Cambridge University Press.
 Lewis, D. J. 1950 *Proc. Roy. Soc. A*, **202**, 81.
 Taylor, Sir Geoffrey 1950 *Proc. Roy. Soc. A*, **201**, 192.