

# SORTING ORDERS, SUBWORD COMPLEXES, BRUHAT ORDER AND TOTAL POSITIVITY

DREW ARMSTRONG AND PATRICIA HERSH

ABSTRACT. In this note we construct a poset map from a Boolean algebra to the Bruhat order which unveils an interesting connection between subword complexes, sorting orders, and certain totally nonnegative spaces. This relationship gives a simple new proof that the proper part of Bruhat order is homotopy equivalent to the proper part of a Boolean algebra — that is, to a sphere. We also obtain a geometric interpretation for sorting orders. We conclude with two new results: that the intersection of all sorting orders is the weak order, and the union of sorting orders is the Bruhat order.

## 1. INTRODUCTION AND TERMINOLOGY

The sorting orders (cf. [Ar]) and subword complexes (cf. [KM]) are combinatorial structures defined in terms of a finite Coxeter group  $W$ . In this note we show how these structures both arise in the context of a certain poset map from a Boolean algebra to the Bruhat order on  $W$ . A consequence of this poset map is a new proof of the homotopy equivalence of the proper part of any Bruhat interval to a sphere.

We also give the following refinement of Armstrong's result from [Ar] that the sorting orders lie in between the weak order and Bruhat order on  $W$ . Given  $w \in W$ , let  $[\hat{0}, w]_R$  denote the weak order interval from  $\hat{0}$  to  $w$ . We show that the intersection of all sorting orders for  $w$  is the weak order on  $[\hat{0}, w]_R$  and that the union of all sorting orders for  $w$  is the Bruhat order on  $[\hat{0}, w]_R$ . These results apply to the whole group by taking  $w$  to be the longest element  $w_\circ$ .

We will need the following concepts.

**1.1. Poset Topology and the Quillen Fiber Lemma.** Given a partially ordered set (poset)  $(P, \leq)$ , we say that  $x \prec y$  is a **cover relation** if we have  $x < y$  and if there does not exist  $z \in P$  such that  $x < z < y$ . Recall that the **order complex**, denoted  $\Delta(P)$ , of a finite poset  $P$  is the

---

1991 *Mathematics Subject Classification.* 05E25, 14M15, 57N60, 20F55.

First author supported by NSF grant DMS-0603567.

Second author was supported by NSF grant DMS-0757935.

simplicial complex whose  $i$ -faces are the chains  $z_0 < z_1 < \cdots < z_i$  of comparable poset elements. Let  $P_{\leq p}$  denote the subposet of elements  $q \in P$  satisfying  $q \leq p$ . Given any simplicial complex  $K$ , let  $F(K)$  be its **face poset**, i.e. the partial order on the faces of  $K$  by containment. More generally, the **closure poset** of a cell complex is the partial order on its cells given by  $\sigma \leq \tau$  if and only if  $\sigma \subseteq \bar{\tau}$ .

*Remark 1.1.* For any simplicial complex  $K$ ,  $\Delta(F(K) \setminus \{\emptyset\})$  is the first barycentric subdivision of  $K$ , hence is homeomorphic to  $K$ .

We recall from Quillen [Qu] the following result:

**Lemma 1.2.** *If  $f : P \rightarrow P'$  is a poset map whose fibers  $f^{-1}(P'_{\leq p})$  are all contractible, then the order complexes of  $P$  and  $P'$  are homotopy equivalent.*

Recall that the **dual poset** of  $P$ , denoted  $P^*$ , is defined by setting  $p \leq q$  in  $P^*$  whenever  $p \geq q$  in  $P$ .

*Remark 1.3.* Since a poset and its dual have the same order complex, we may restate the Quillen Fiber Lemma by requiring contractibility of  $f^{-1}(P'_{\geq p})$  for each  $p \in P'$ .

Define the **closed interval**  $[u, v]$  of a poset  $P$  as  $\{z \in P \mid u \leq z \leq v\}$  and the **open interval**  $(u, v)$  as  $\{z \in P \mid u < z < v\}$ .

**1.2. Sorting Orders.** We recall from [Ar] the definition of the sorting orders. Let  $W$  be a finite Coxeter group with simple generators  $S = \{s_1, \dots, s_n\}$ . Let  $Q$  be a word in the generators whose product is  $w \in W$ . If there is no such word with fewer symbols, we call  $Q$  **reduced**; the **length**  $\ell(w)$  is the number of symbols in a reduced word for  $w$ . We define the **(right) weak order** on  $W$  by setting  $u \leq_R v$  if there exists a reduced word for  $v$  such that  $u$  occurs as a prefix. The **Bruhat order** is defined by setting  $u \leq_B v$  if there exists a reduced word for  $v$  such that  $u$  occurs as an arbitrary subword.

Now fix a reduced word  $Q$  for some element  $w \in W$ . It turns out that the elements which occur as subwords of  $Q$  are the elements of the Bruhat interval  $[\hat{0}, w]_B$ . To each element  $u \in [\hat{0}, w]_B$  we associate a subset  $Q(u)$  of the indices of  $Q$  whose corresponding subword is reduced for  $u$  and which is the lexicographically first subset with this property. The  $Q$ -**sorting order** is defined by setting  $u \leq_Q v$  whenever  $Q(u) \subseteq Q(v)$ . Armstrong [Ar] proved the following.

**Theorem 1.4** (Ar, Theorem 4.2). *Let  $Q$  be a reduced word for  $w \in W$ . Given  $u$  and  $v$  in the Bruhat interval  $[\hat{0}, w]_B$ , we have*

$$u \leq_R v \quad \Rightarrow \quad u \leq_Q v \quad \Rightarrow \quad u \leq_B v.$$

That is, the  $Q$ -sorting order is between the weak and Bruhat orders.

**1.3. The 0-Hecke Algebra.** Given a finite Coxeter group  $W$  with generators  $S = \{s_1, \dots, s_n\}$ , recall that the corresponding 0-Hecke algebra has a generating set  $X = \{x_1, \dots, x_n\}$  with the following relations (up to a sign). Each Hecke generator is idempotent, namely satisfies  $x_i^2 = x_i$ , whereas the Coxeter generators are involutions  $s_i^2 = e$ . Also, for each Coxeter braid relation  $(s_i s_j)^{m(i,j)} = e$  we get a corresponding Hecke braid relation of the form  $x_i x_j x_i \cdots = x_j x_i x_j \cdots$ , with  $m(i, j)$  alternating terms on each side. Recall from [BB]:

**Theorem 1.5** (BB, Theorem 3.3.1). *Let  $(W, S)$  be a Coxeter group generated by  $S$ . Consider  $w \in W$ .*

- (1) *Any expression  $s_{i_1} s_{i_2} \cdots s_{i_d}$  for  $w$  can be transformed into a reduced expression for  $w$  by a sequence of nil-moves and braid-moves.*
- (2) *Every two reduced expressions for  $w$  can be connected via a sequence of braid-moves.*

This implies that an arbitrary word in the 0-Hecke generators may be reduced by a sequence of nil-moves  $x_i^2 \rightarrow x_i$  and braid moves  $x_i x_j x_i \cdots \rightarrow x_j x_i x_j \cdots$ . A reduced word in the 0-Hecke generators corresponds to a reduced word in the Coxeter generators by switching occurrences of  $x_i$  with  $s_i$ . Note that likewise nonreduced words in the 0-Hecke algebra correspond to nonreduced words in the associated Coxeter group. Our upcoming poset map from a Boolean algebra to Bruhat order will take the subexpressions of a fixed reduced expression in the 0-Hecke algebra and send them to Coxeter group elements.

**1.4. Subword Complexes.** We recall from [KM] and [KM2] the definition of a subword complex. Let  $Q$  be a (not necessarily reduced) word in the generators and let  $w \in W$  be an arbitrary element of the Coxeter group. The **subword complex**  $\Delta(Q, w)$  has as its ground set the indexing positions of the list  $Q$  and its facets are the complementary sets to subwords of  $Q$  that are reduced expressions for  $w$ . Since the set of faces of a simplicial complex is closed under taking subsets, the faces of  $\Delta(Q, w)$  are precisely the complements of the subwords of  $Q$  that contain a reduced expression for  $w$ .

Knutson and Miller [KM] proved that a subword complex is vertex decomposable — hence shellable — and they gave a characterization of the homotopy type. To describe this we will need the notion of a **Demazure product**. For a commutative ring  $R$ , define a free  $R$ -module with generators indexed by the Coxeter group  $\{e_w : w \in W\}$  and with multiplication as follows. Let  $w \in W$  be a group element and let  $s \in S$

be a simple generator. Let  $\ell : W \rightarrow \mathbb{Z}$  denote the word length on  $W$  with respect to the generators  $S$ . If  $s$  is a right descent of  $w$  — that is, if  $\ell(w) > \ell(ws)$  — we set  $e_w e_s = e_w$ , and otherwise we set  $e_w e_s = e_{ws}$ .

*Remark 1.6.* Notice that the Demazure product is equivalent to the multiplication rule for the 0-Hecke algebra from the previous section.

**Theorem 1.7** (KM, Corollary 3.8). *The subword complex  $\Delta(Q, w)$  is either a ball or a top-dimensional sphere. It is a sphere if and only if the Demazure product applied to  $Q$  yields exactly  $w$ .*

In the language of Section 2, this means that we get a ball unless a certain poset map applied to  $Q$  yields exactly the group element  $w$ , rather than yielding an element strictly above  $w$  in Bruhat order.

Subword complexes arose in [KM2] as the Stanley-Reisner complexes of initial ideals for the (determinantal) vanishing ideals of matrix Schubert varieties. Shellability of subword complexes provides one way (of many) to explain why matrix Schubert varieties are Cohen-Macaulay, and the combinatorics of subword complexes provides insight into formulas for Grothendieck polynomials which are the  $K$ -polynomials of matrix Schubert varieties.

**1.5. Stratified Totally Nonnegative Spaces.** Recall that a matrix is totally nonnegative if each minor is nonnegative. It was shown by Whitney ([Wh]) that every  $n \times n$  totally nonnegative, upper triangular matrix with 1's on the diagonal can be written as a product of matrices  $\{x_i(t) : t \in \mathbb{R}_{\geq 0}, 1 \leq i \leq n-1\}$  where  $x_i(t) = I_n + tE_{i,i+1}$  for  $I_n$  the identity matrix and  $E_{i,i+1}$  the matrix whose only nonzero entry is a 1 which is in row  $i$  and column  $i+1$ . Lusztig generalized this type A notion to all semisimple, simply connected algebraic groups over  $\mathbb{C}$  split over  $\mathbb{R}$ . Lusztig showed for any reduced word  $(i_1, \dots, i_d)$  that the set  $Y_{s_{i_1} \dots s_{i_d}}$  of points  $\{x_{i_1}(t_1) \cdots x_{i_d}(t_d) : t_1, \dots, t_d \in \mathbb{R}_{>0}\}$  is homeomorphic to an open ball. Now consider the decomposition of the closure of this space, namely  $\{x_{i_1}(t_1) \cdots x_{i_d}(t_d) : t_1, \dots, t_d \in \mathbb{R}_{\geq 0}\}$ , into cells defined by which subset of parameters are nonzero. Fomin and Shapiro showed that the closure poset for this decomposition is the Bruhat order, and conjectured that this stratified space is a regular CW complex; this was recently proven by Hersh [He] via a map on points of a space which induces a map on cells, namely the poset map of the next section.

## 2. A POSET MAP FROM SUBWORDS TO BRUHAT ORDER

Let us now define a poset map from a Boolean algebra to Bruhat order which is derived from Lusztig's map  $(t_1, \dots, t_d) \rightarrow x_{i_1}(t_1) \cdots x_{i_d}(t_d)$ ,

where  $(i_1, \dots, i_d)$  is any fixed reduced word. First note that setting the parameter  $t_j$  to 0 amounts to replacing the matrix  $x_{i_j}(t_j)$  by the identity matrix, essentially choosing the subword of  $(i_1, \dots, i_d)$  with  $i_j$  eliminated, hinting at a connection to the subword complexes of [KM]. The relations  $x_i(t_1)x_i(t_2) = x_i(t_1 + t_2)$  and

$$x_i(t_1)x_{i+1}(t_2)x_i(t_3) = x_{i+1}\left(\frac{t_2t_3}{t_1+t_3}\right)x_i(t_1+t_3)x_{i+1}\left(\frac{t_1t_2}{t_1+t_3}\right)$$

along with similar relations corresponding to higher degree braid relations (cf. [FZ]) allow us to use the relations in the 0-Hecke algebra to determine how to assign points  $(t_1, \dots, t_d) \in \mathbb{R}_{\geq 0}^d$  to cells in  $Y_{s_{i_1} \dots s_{i_d}}$ , i.e. to elements of Bruhat order.

The poset map we now analyze comes from choosing a subset of the parameters  $\{t_1, \dots, t_d\}$  to set to 0, taking the resulting subword of  $(i_1, \dots, i_d)$  and determining the Coxeter group element which has this as one of its (not necessarily reduced) words in the 0-Hecke algebra. That is:

**Definition 2.1.** Let  $Q = (i_1, \dots, i_d)$  be a reduced word for a Coxeter group element  $w \in W$ . Define a map  $f$  from the Boolean algebra  $2^Q$  to the Bruhat interval  $[\hat{0}, w]_B$  as follows. Given a subset  $\{j_1, \dots, j_r\}$  of the indices  $\{1, \dots, d\}$  of  $Q$ , map this to a (possibly non-reduced) expression  $x_{i_{j_1}} \cdots x_{i_{j_r}}$  in the 0-Hecke generators; use braid moves and nil-moves to obtain a reduced 0-Hecke expression; then map this to a Coxeter group element by replacing each  $x_k$  with the corresponding Coxeter group generator  $x_k$ .

For example, consider the Coxeter group of type  $A_3$  with generators  $\{s_1, s_2, s_3\}$ , and consider the reduced word  $Q = (1, 2, 3, 1, 2, 1)$  for the longest element  $w_o = s_1s_2s_3s_1s_2s_1$ . The index set  $\{1, 2, 4, 5\} \in 2^Q$  gets mapped to the 0-Hecke word  $x_1x_2x_1x_2$ , which reduces to

$$x_1(x_2x_1x_2) \rightarrow x_1(x_1x_2x_1) \rightarrow (x_1x_1)x_2x_1 \rightarrow x_1x_2x_1.$$

Finally, this maps to the group element  $s_1s_2s_1$ .

We have the following results.

**Proposition 2.2.** *Each fiber of  $f$  contains exactly one element of the  $Q$ -sorting order, and every element of the  $Q$ -sorting order belongs to some fiber of  $f$ . The subset of the Boolean algebra  $2^Q$  comprised of these elements is isomorphic to the  $Q$ -sorting order.*

*Proof.* This is immediate from the definition of the sorting order.  $\square$

**Proposition 2.3.** *For  $u \in [\hat{0}, w]_B$ , the fiber  $f^{-1}([u, w]_B)$  is dual to the face poset of the subword complex  $\Delta(Q, u)$ . The fiber  $f^{-1}((u, w)_B)$  is*

dual to the face poset for  $\partial(\Delta(Q, u)) \setminus \{\emptyset\}$ , i.e. for the boundary of the subword complex  $\Delta(Q, u)$  with the empty set removed.

*Proof.* For  $u \in [\hat{0}, w]_B$ , note that the elements  $S = \{j_1, j_2, \dots, j_r\} \in 2^Q$  with  $f(S) = u$  are exactly those such that  $x_{j_1}x_{j_2} \cdots x_{j_r}$  reduces via braid moves and nil-moves to a reduced expression  $x_{i_1}x_{i_2} \cdots x_{i_t}$  such that  $s_{i_1}s_{i_2} \cdots s_{i_t} = u$ . In particular, the minimal such  $S$  are precisely the subwords of  $Q$  which are reduced words for  $u$ . Thus the fiber  $f^{-1}(u)$  consists of all subwords of  $Q$  which contain a reduced expression for  $u$ . This is exactly the dual of the subword complex  $\Delta(Q, u)$ .

To see the latter claim, notice that a face  $F$  in  $f^{-1}([u, w]_B)$  has the same Demazure product as  $u$  if and only if  $F$  is in the interior of  $\Delta(Q, u)$ , because we will show that every face  $G$  of  $\Delta(Q, u)$  which contains  $F$  and has dimension exactly one less than the facets of  $\Delta(Q, u)$  is itself in the interior of  $\Delta(Q, u)$ . This follows from the fact that any such  $G$  must have the same Demazure product as  $u$  while involving exactly one more letter than a reduced expression for  $u$ , implying  $G$  is contained in exactly two facets of  $\Delta(Q, u)$ , hence in its interior.  $\square$

**Corollary 2.4.** *The order complex for the open Bruhat interval  $(\hat{0}, w)_B$  is homotopy equivalent to the order complex for the proper part of the Boolean algebra  $2^Q$  of dimension  $\ell(w)$ , hence to a sphere  $S^{\ell(w)-2}$ . More generally, the order complex for the open Bruhat interval  $(u, w)_B$  is homotopy equivalent to a sphere  $S^{\ell(w)-\ell(u)-2}$ .*

*Proof.* This is a simple application of the Quillen Fiber Lemma, namely Lemma 1.2, which originally appeared in [Qu]. Proposition 2.3 shows that the fibers of our poset map are face posets of subword complexes. It was shown in [KM] that subword complexes are shellable. By Theorem 1.7, we see in particular that all fibers for the proper part of the interval  $[\hat{0}, w]_B$  are contractible, since the fact that the maximal element of our Boolean algebra is a reduced word means that any proper subset has distinct Demazure product from it. Thus, by Remark 1.1 the order complexes of the fibers in this case are homeomorphic to contractible subword complexes. This gives the requisite contractibility of fibers, completing our proof of the first claim.

The Quillen Fiber Lemma also tells us for any open Bruhat interval  $(u, w)_B$  that its order complex is homotopy equivalent to the order complex of the subposet  $f^{-1}(u, w)$  of a Boolean algebra. By Proposition 2.3, this preimage is the boundary of a ball, hence is a sphere. Its dimension is immediate from the definition of subword complexes.  $\square$

In [He], Hersh proved that the stratified spaces from Section 1.5 are regular CW complexes with Bruhat order as their closure posets. Her

method was to start with a simplex, namely

$$\{(t_1, \dots, t_d) \in \mathbb{R}_{\geq 0}^d : t_1 + \dots + t_d = 1\},$$

having the Boolean algebra as its closure poset, and then perform a series of collapses preserving homeomorphism type and regularity. The Bruhat order is the closure poset for the regular CW complex obtained at the end of this process. Our poset map describes which faces of the simplex are mapped to a particular cell in the regular CW complex having Bruhat order as its closure poset.

**Example 2.5.** Given the reduced word  $(1, 2, 1)$  in type  $A_2$ , [He] performs a single collapse on the simplex  $\{(t_1, t_2, t_3) \in \mathbb{R}_{\geq 0}^3 : t_1 + t_2 + t_3 = 1\}$ , eliminating the open cell  $\{(t_1, 0, t_3) \in \mathbb{R}_{\geq 0}^3 : t_1 + t_3 = 1\}$  by identifying points which have  $t_1 + t_3 = k$  for any constant  $k$ ; in this case we just have  $k = 1$ , but in larger examples we have a family of constants  $k$  ranging from 0 to 1. In effect, this moves the cell  $\{(0, 0, t_3) \in \mathbb{R}_{\geq 0}^3 : t_3 = 1\}$  across the cell  $\{(t_1, 0, t_3) \in \mathbb{R}_{\geq 0}^3 : t_1 + t_3 = 1\}$  being collapsed, thereby identifying the cell  $\{(0, 0, t_3) \in \mathbb{R}_{\geq 0}^3 : t_3 = 1\}$  with the cell  $\{(t_1, 0, 0) \in \mathbb{R}_{\geq 0}^3 : t_1 = 1\}$ , reflecting the fact that  $s_1 \cdot 1 \cdot 1$  and  $1 \cdot 1 \cdot s_1$  are both reduced words for the same Coxeter group element.

Some cell incidences are present from the beginning to the end of this collapsing process, whereas others are created along the way. The sorting order captures this distinction:

**Proposition 2.6.** *The sorting order on a finite Coxeter group is generated by precisely those covering relations on Bruhat order between cells that were already incident in the simplex, i.e. it leaves out exactly those cell incidences that were introduced by collapses.*

*Proof.* Consider a subword  $P = (i_{j_1}, \dots, i_{j_k}) \in 2^Q$  of the given word  $Q = (i_1, \dots, i_d)$  such that  $\{j_1, \dots, j_k\}$  is not a  $Q$ -sorting word — that is, it is not lexicographically first among subwords that give rise to the group element  $f(P)$ . Following the language of [He], this means that  $P$  must include the larger element of some deletion pair in a word  $P \vee P'$  obtained from  $P$  by adding exactly one letter to obtain a subword of  $Q$ . This means that the larger element of the deletion pair may be exchanged for the smaller one to obtain a lexicographically smaller reduced word for the group element  $f(P)$ . In particular, the face given by  $P$  gets identified with a lexicographically earlier choice  $P'$  by a collapsing step in [He] which collapses a higher dimensional cell  $P \vee P'$  including both elements of the deletion pair by moving  $P$  across  $F$  so as to identify it with  $P'$ .

Thus, the faces given by the lexicographically first reduced expressions are essentially held fixed (ignoring unimportant stretching homeomorphisms on them) by the collapsing process of [He] while all other faces are collapsed onto these, creating new cell incidences in the process. The incidences among the lexicographically first reduced expressions are inclusions, which is precisely the definition of the  $Q$ -sorting order. Examining the collapsing process in [He], we see that these are exactly the incidences that are present from the beginning to the end of the collapsing process — that is, left unchanged by it. All other incidence relations in Bruhat order are introduced by collapses.  $\square$

*Remark 2.7.* Proposition 2.6 gives a way to think about the  $Q$ -sorting order as a closure poset, and also a geometric explanation for the fact that its cover relations are a subset of Bruhat covers.

**Corollary 2.8.** *The covering relations in the  $Q$ -sorting order are a proper subset of the covering relations the Bruhat interval  $[\hat{0}, w]_B$ .*

Finally, we establish two new properties of the sorting orders.

### 3. UNIONS AND INTERSECTIONS OF SORTING ORDERS

Given an element  $w \in W$  of a finite Coxeter group, let  $\text{red}(w)$  denote the set of reduced words for  $w$  in the generators  $S$ . For each  $Q \in \text{red}(w)$  there is a corresponding  $Q$ -sorting order on the elements of the Bruhat interval  $[\hat{0}, w]_B$ . In this section, however, we will consider the  $Q$ -sorting order as restricted to the elements of the interval  $[\hat{0}, w]_R$  in (right) *weak* order. We will show that the intersection of  $Q$ -sorting orders, over  $Q \in \text{red}(w)$ , is the weak order on  $[\hat{0}, w]_R$  and the union of these  $Q$ -sorting orders is the Bruhat order on  $[\hat{0}, w]_R$ . Our results apply to the entire group  $W$  by taking the longest element  $w = w_\circ$ .

**Theorem 3.1.** *The intersection over  $Q \in \text{red}(w)$  of  $Q$ -sorting orders is the weak order on the weak interval  $[\hat{0}, w]_R$ .*

*Proof.* Since weak order is contained in each  $Q$ -sorting order (see Theorem 1.4), it is contained in the intersection. Recall also that each  $Q$ -sorting cover  $u \prec_Q v$  is a Bruhat cover  $u \prec_B v$  (Theorem 1.4). Thus, we must show: Given  $u$  and  $v$  in  $[\hat{0}, w]_R$  such that  $u \prec_B v$  and  $u \not\prec_R v$ , there exists a reduced word  $Q \in \text{red}(w)$  such that  $u \not\prec_Q v$ .

Let  $Q' \in \text{red}(u)$  be any reduced word for  $u$ . Since we have  $u \leq_R w$  by assumption, there exists a reduced word  $Q \in \text{red}(w)$  for  $w$  which contains  $Q'$  as a prefix. We claim that  $u \not\prec_Q v$  in  $Q$ -sorting order. Indeed, the  $Q$ -sorting subword  $Q(u) \subseteq Q$  corresponding to  $u$  is just the prefix  $Q' \subseteq Q$ . Let  $Q(v) \subseteq Q$  be the  $Q$ -sorting word for  $v$ ; that is,



the lex-first reduced word for  $v$  as a subword of  $Q$ . Suppose now that  $u \leq_Q v$ ; i.e., that  $Q(u) \subseteq Q(v)$ . Then  $Q(v)$  is a reduced word for  $v$  containing the reduced word  $Q(u)$  for  $u$  as a prefix, which implies that  $u \leq_R v$ . This is a contradiction.  $\square$

**Theorem 3.2.** *The union of over  $Q \in \text{red}(w)$  of  $Q$ -sorting orders is the Bruhat order on the weak interval  $[\hat{0}, w]_R$ .*

*Proof.* Given  $u$  and  $v$  in  $[\hat{0}, w]_R$  such that  $u \prec_B v$  is a Bruhat cover, we must find a reduced word  $Q \in \text{red}(w)$  such that  $u \leq_Q v$ .

Since  $v \leq_R w$  in weak order, there exists a reduced word for  $v$  which is a prefix of  $Q$ . Since a prefix is clearly lex-first, this prefix is the  $Q$ -sorting word  $Q(v) \subseteq Q$ . Suppose that  $v$  has length  $k$ , so that  $Q(v)$  corresponds to positions  $\{1, 2, \dots, k\}$ . By the subword definition of Bruhat order above, there exists a reduced word  $Q'$  for  $u$  in positions  $\{1, 2, \dots, k\} - \{i\}$  for some  $1 \leq i \leq k$ . We claim that  $u \leq_Q v$ . Indeed, we already have  $Q' \subseteq Q(v)$ . The  $Q$ -sorting word  $Q(u)$  for  $u$  is a reduced word for  $u$  which precedes  $Q'$  lexicographically. Since  $Q(v)$  is a prefix of  $Q$  we must have  $Q(u) \subseteq Q(v)$ , or  $u \leq_Q v$ .  $\square$

For example, consider the Coxeter group  $W$  of type  $B_2$  with generators  $\{1, 2\}$  and longest element  $w_o = 1212 = 2121$ . In this case we have

$$\text{red}(w_o) = \{Q_1 = (1, 2, 1, 2), Q_2 = (2, 1, 2, 1)\}.$$

Figure 1 displays the weak order,  $Q_1$ -sorting order,  $Q_2$ -sorting order, and Bruhat order on the full group. Here we have used zeroes as placeholders, to indicate the indices not in a given word. Note that the weak order is the intersection and the Bruhat order is the union of the two sorting orders. Next, observe that there is only one reduced word for the element  $w = 212$ , namely  $Q = (2, 1, 2)$ . Note that the  $Q$ -sorting order is just the interval  $[\hat{0}, 212]_{Q_2}$  in  $Q_2$ -sorting order. Note also that this order coincides *neither* with the weak *nor* the Bruhat order on the set  $[\hat{0}, 212]_Q = [\hat{0}, 212]_B$ . Our above results instead tell us that the weak order,  $Q$ -sorting order, and Bruhat order all coincide on the *weak* interval  $[\hat{0}, 212]_R$ .

#### 4. ACKNOWLEDGMENTS

The authors thank Ezra Miller for helpful comments.

#### REFERENCES

- [Ar] D. Armstrong, The sorting order on a Coxeter group, to appear in Journal of Combin. Theory, Ser. A

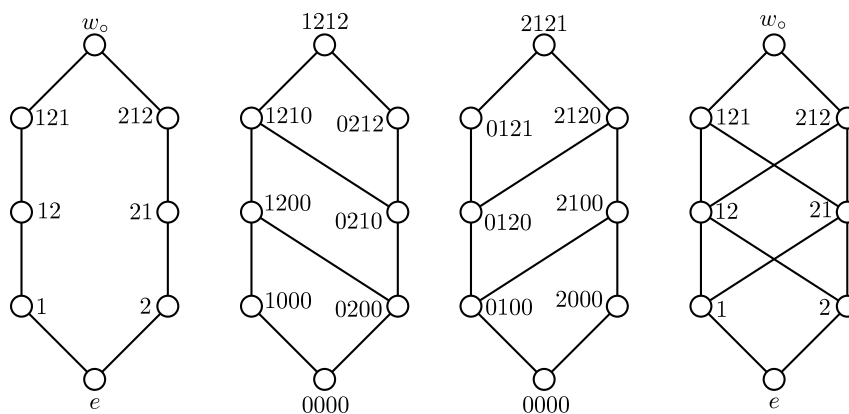

FIGURE 1. The weak order,  $Q_1$ -sorting order,  $Q_2$ -sorting order, and Bruhat order

- [Bj] A. Björner, Posets, Regular CW complexes and Bruhat order, *European J. Combin.* **5** (1984), no. 1, 7–16.
- [BB] A. Björner and F. Brenti, *Combinatorics of Coxeter groups*, Graduate Texts in Mathematics **231**, Springer, 2005.
- [BW] A. Björner and M. Wachs, Bruhat order of Coxeter groups and shellability, *Adv. Math.* **43** (1982), no. 1, 87–100.
- [FS] S. Fomin and M. Shapiro, Stratified spaces formed by totally positive varieties. Dedicated to William Fulton on the occasion of his 60th birthday. *Michigan Math. J.* **48** (2000), 253–270.
- [FZ] S. Fomin and A. Zelevinsky, Double Bruhat cells and total positivity, *Journal Amer. Math. Soc.*, **12** (April 1999), no. 2, 335–380.
- [He] P. Hersh, Regular cell complexes in total positivity, submitted.
- [Hu] J. Humphreys, *Reflection groups and Coxeter groups*, Cambridge studies in advanced mathematics **29**, Cambridge University Press, 1990.
- [KM] A. Knutson and E. Miller, Subword complexes in Coxeter groups, *Adv. Math.*, **184**, (2004), no. 1, 161–176.
- [KM2] A. Knutson and E. Miller, Gröbner geometry of Schubert polynomials, *Annals of Math.*, **161**, (2005), 1245–1318.
- [Qu] D. Quillen, Homotopy properties of the poset of nontrivial  $p$ -subgroups of a group, *Advances in Math.* **28** (1978), 101–128.
- [Wh] A. M. Whitney, A reduction theorem for totally positive matrices, *J. d’Analyse Math.* **2** (1952), 88–92.

DEPARTMENT OF MATHEMATICS, UNIVERSITY OF MIAMI, 1365 MEMORIAL DRIVE, UNGAR 515, CORAL GABLES, FL 33146

*E-mail address:* [armstrong@math.miami.edu](mailto:armstrong@math.miami.edu)

BOX 8205, NORTH CAROLINA STATE UNIVERSITY, RALEIGH, NC 27695-8205

*E-mail address:* [plhersh@ncsu.edu](mailto:plhersh@ncsu.edu)