

## SAMPLE INTERACTIVE LECTURE DEMONSTRATION PREDICTION SHEET FOR SEIITE ALOP WORKSHOP

**Directions:** Students would normally write their names at the top of this sheet, and the sheet would be collected at the end of class but not graded. Please behave as a student and write your predictions in the spaces provided when asked to.

**Note:** This is a sample of ILDs prepared for this workshop. They do not represent a complete, coherent sequence. Normally an ILD sequence consists of 6-7 related demonstrations in a single physics topic area. Actual ILD sequences can be found in the book *Interactive Lecture Demonstrations* a PDF of which you can download at: <https://pages.uoregon.edu/sokoloff/ILDbook0116.pdf>.

### Workshop Session 1

#### Activity from Module 1: Introduction to Geometrical Optics

**Image Formation Demonstration 1:** You have a converging lens. An object in the shape of an arrow is positioned a distance larger than the focal length to the left of the lens, as shown on the right. Draw several rays from the head of the arrow and several rays from the foot of the arrow to show how the image of the candle is formed by the lens.

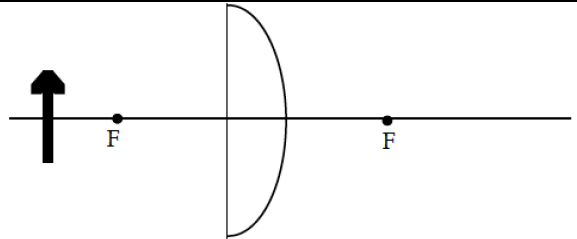

Is this a real or a virtual image?

**Image Formation Demonstration 2:** What will happen to the image if you block the top half of the lens with a card? Answer in words and show what happens on the diagram on the right by making any changes needed in the rays you drew above.

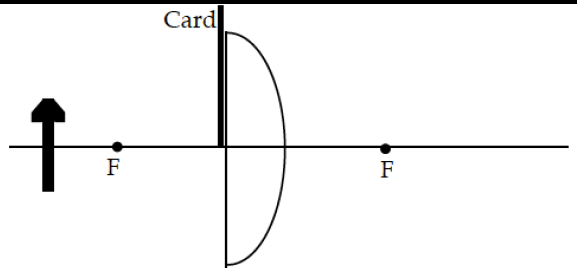

**Image Formation Demonstration 3:** What will happen to the image if you block the top half of the object with a card? Answer in words and show what happens on the diagram on the right by making any changes needed in the rays you drew above for Demonstration 1.

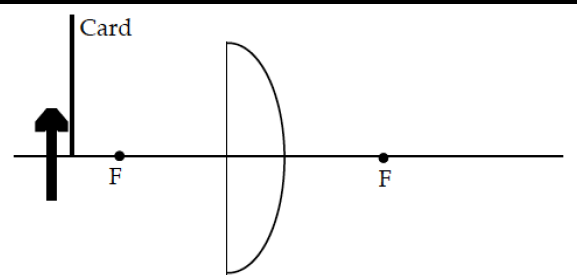

#### Activity from Module 2: Lenses and Optics of the Eye

**Myopia Demonstration:** Myopia or nearsighted-ness is caused by either (a) the eyeball length (distance from cornea to retina) being too long or (b) the power of the eye's optics being too strong. In both cases, the image of a distant object will no longer be sharply focused on the retina but rather in front of it. What kind of lens would you need to bring the image back into focus on the screen (retina)—positive or negative?

### Activity from Module 3: Interference and Diffraction

**Diffraction Demonstration:** Suppose that the red laser is replaced by a green one. Will the pattern on the wall be changed, and if so, how?

### Workshop Session 2

### Activity from Module 4: Atmospheric Optics

**Scattering of Light in Milky Water Demonstration:**

**4A.1** Initially, what will you see looking through the front face of the tank before any milk is added?

As drops of milk are added to the water...

**4A.2** Will the outline of the light source change?

**4A.3** Will the color of the water on either side of the light source change?

**4A.4** Will the color of the light source change?

**4A.5** What would you see if we replaced the single white-light source, with two light sources (one red and one blue), separated by a few centimeters?

**Crossed Polaroids Demonstration:**

**4B.1** While looking directly at the light source, predict what you will see if the front polarizing filter is rotated through 90 degrees relative to the back polarizing filter.

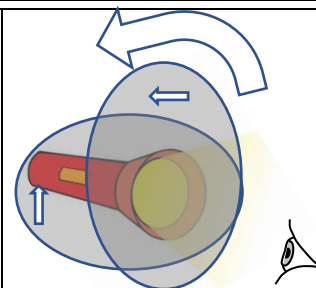

**Polarization of Scattered Light Demonstration:**

**4C.1** Initially, before you insert the linearly polarizing filter, what will you see looking through the side face of the tank? Will you see the light beam? What colour is the fluid mixture?

With the linearly polarizing filter in place (with its optical axis pointing vertically)

**4C.2** Will you see any light scattered from the light beam?

With the linearly polarizing filter in place (with its optical axis pointing horizontally)

**4C.3** Will you see any light scattered from the light beam?

**Activity from Modules 5 A & B: Optical Data Transmission and Wavelength Division Multiplexing**

Initially, the transmitter and receiver are facing each other and close together. When the switch is closed and the LED illuminates....

**5A.1** Will the sound from the phototransistor buzzer be loud or soft?

Next, we move the transmitter and receiver far apart, but still facing each other.

When the switch is closed and the LED illuminates....

**5A.2** Will the sound from the phototransistor buzzer be louder, the same, or softer (than the initial case)?

Finally, while the transmitter and receiver are still far apart, we connect a long optical fibre between the LED and the phototransistor.

When the switch is closed and the LED illuminates....

**5A.3** Will the sound from the phototransistor buzzer be louder, the same, or softer (than the initial case)?

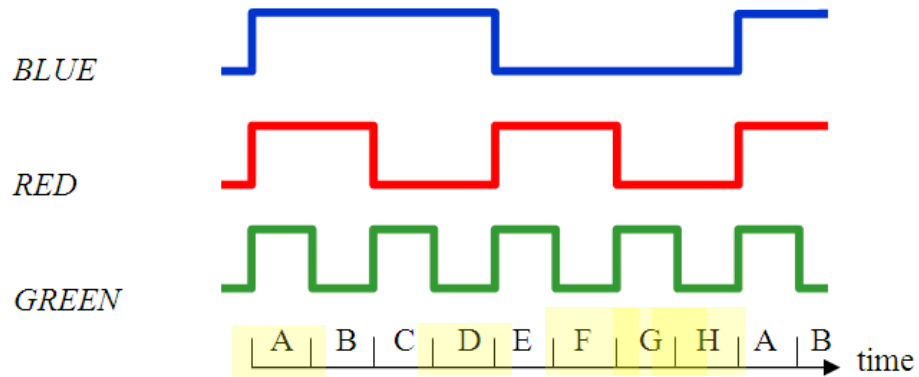

**5B.1** Sketch un-scattered & diffracted images for time A

**5B.2** Sketch un-scattered & diffracted images for time D

**5B.3** Sketch un-scattered & diffracted images for time F

**5B.4** Sketch un-scattered & diffracted images for time G

**5B.5** Sketch un-scattered & diffracted images for time H