



UNIVERSAL 4-BIT SHIFT REGISTER

The SN54/74LS195A is a high speed 4-Bit Shift Register offering typical shift frequencies of 39 MHz. It is useful for a wide variety of register and counting applications. It utilizes the Schottky diode clamped process to achieve high speeds and is fully compatible with all Motorola TTL products.

- Typical Shift Right Frequency of 39 MHz
- Asynchronous Master Reset
- J, K Inputs to First Stage
- Fully Synchronous Serial or Parallel Data Transfers
- Input Clamp Diodes Limit High Speed Termination Effects

CONNECTION DIAGRAM DIP (TOP VIEW)

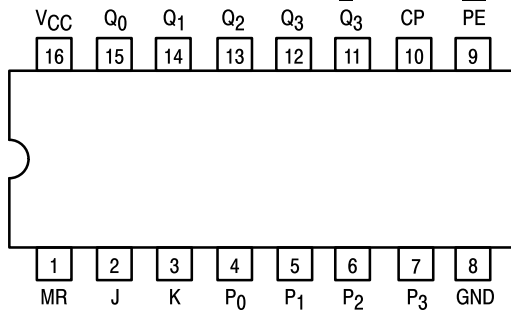

NOTE:
The Flatpak version has the same pinouts (Connection Diagram) as the Dual In-Line Package.

PIN NAMES

| | |
|---------------------------------|--|
| PE | Parallel Enable (Active LOW) Input |
| P ₀ - P ₃ | Parallel Data Inputs |
| J | First Stage J (Active HIGH) Input |
| K | First Stage K (Active LOW) Input |
| CP | Clock (Active HIGH Going Edge) Input |
| MR | Master Reset (Active LOW) Input |
| Q ₀ - Q ₃ | Parallel Outputs (Note b) |
| Q ₃ | Complementary Last Stage Output (Note b) |

LOADING (Note a)

| | HIGH | LOW |
|---------------------------------|----------|--------------|
| PE | 0.5 U.L. | 0.25 U.L. |
| P ₀ - P ₃ | 0.5 U.L. | 0.25 U.L. |
| J | 0.5 U.L. | 0.25 U.L. |
| K | 0.5 U.L. | 0.25 U.L. |
| CP | 0.5 U.L. | 0.25 U.L. |
| MR | 0.5 U.L. | 0.25 U.L. |
| Q ₀ - Q ₃ | 10 U.L. | 5 (2.5) U.L. |
| Q ₃ | 10 U.L. | 5 (2.5) U.L. |

NOTES:

- a. 1 TTL Unit Load (U.L.) = 40 μ A HIGH/1.6 mA LOW.
 b. The Output LOW drive factor is 2.5 U.L. for Military (54) and 5 U.L. for Commercial (74) Temperature Ranges.

SN54/74LS195A

UNIVERSAL 4-BIT SHIFT REGISTER

LOW POWER SCHOTTKY

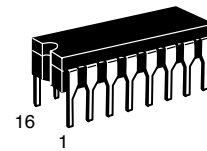

J SUFFIX
CERAMIC
CASE 620-09

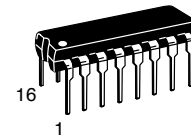

N SUFFIX
PLASTIC
CASE 648-08

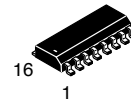

D SUFFIX
SOIC
CASE 751B-03

ORDERING INFORMATION

| | |
|------------|---------|
| SN54LSXXXJ | Ceramic |
| SN74LSXXXN | Plastic |
| SN74LSXXXD | SOIC |

LOGIC SYMBOL

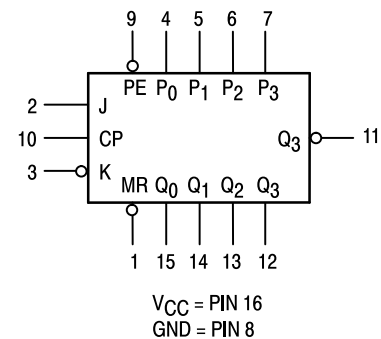

SN54/74LS195A

LOGIC DIAGRAM

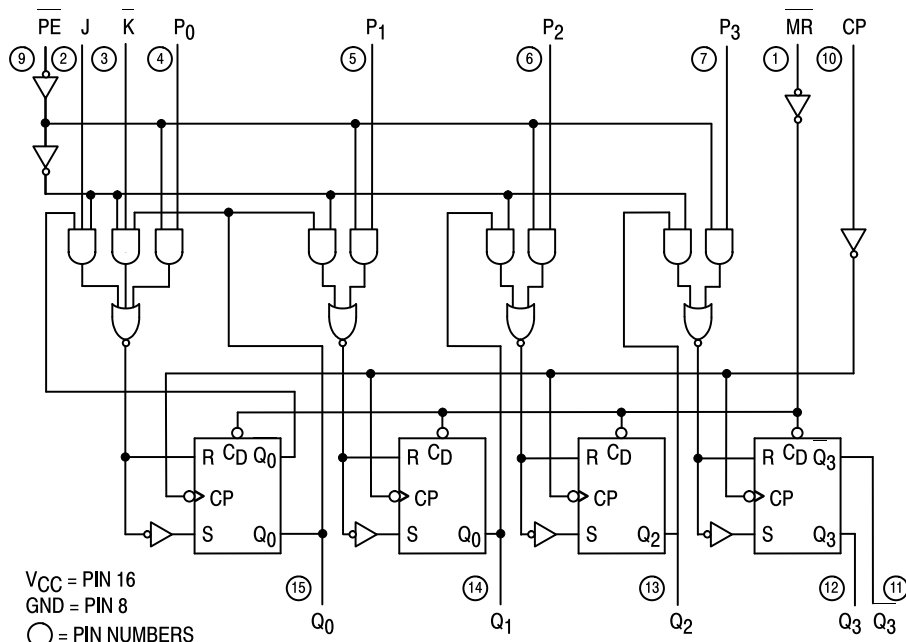

FUNCTIONAL DESCRIPTION

The Logic Diagram and Truth Table indicate the functional characteristics of the LS195A 4-Bit Shift Register. The device is useful in a wide variety of shifting, counting and storage applications. It performs serial, parallel, serial to parallel, or parallel to serial data transfers at very high speeds.

The LS195A has two primary modes of operation, shift right ($Q_0 \rightarrow Q_1$) and parallel load which are controlled by the state of the Parallel Enable (PE) input. When the PE input is HIGH, serial data enters the first flip-flop Q_0 via the J and K inputs and is shifted one bit in the direction $Q_0 \rightarrow Q_1 \rightarrow Q_2 \rightarrow Q_3$ following each LOW to HIGH clock transition. The JK inputs provide the flexibility of the JK type input for special applications, and the simple D type input for general applications by tying the two

pins together. When the \overline{MR} input is LOW, the LS195A appears as four common clocked D flip-flops. The data on the parallel inputs P_0, P_1, P_2, P_3 is transferred to the respective Q_0, Q_1, Q_2, Q_3 outputs following the LOW to HIGH clock transition. Shift left operations ($Q_3 \leftarrow Q_2$) can be achieved by tying the Q_n Outputs to the P_{n-1} inputs and holding the PE input LOW.

All serial and parallel data transfers are synchronous, occurring after each LOW to HIGH clock transition. Since the LS195A utilizes edge-triggering, there is no restriction on the activity of the J, K, P_n and PE inputs for logic operation — except for the set-up and release time requirements.

A LOW on the asynchronous Master Reset (MR) input sets all Q outputs LOW, independent of any other input condition.

MODE SELECT — TRUTH TABLE

| OPERATING MODES | INPUTS | | | | | OUTPUTS | | | | |
|---------------------------|--------|----|---|---|-------|-----------------|-------|-------|-------|-------|
| | MR | PE | J | K | P_n | Q_0 | Q_1 | Q_2 | Q_3 | Q_3 |
| Asynchronous Reset | L | X | X | X | X | L | L | L | L | H |
| Shift, Set First Stage | H | h | h | h | X | H | q_0 | q_1 | q_2 | q_2 |
| Shift, Reset First | H | h | l | l | X | \underline{L} | q_0 | q_1 | q_2 | q_2 |
| Shift, Toggle First Stage | H | h | h | l | X | q_0 | q_0 | q_1 | q_2 | q_2 |
| Shift, Retain First Stage | H | h | l | h | X | q_0 | q_0 | q_1 | q_2 | q_2 |
| Parallel Load | H | l | X | X | p_n | p_0 | p_1 | p_2 | p_3 | p_3 |

L = LOW voltage levels

H = HIGH voltage levels

X = Don't Care

l = LOW voltage level one set-up time prior to the LOW to HIGH clock transition.

h = HIGH voltage level one set-up time prior to the LOW to HIGH clock transition.

p_n (q_n) = Lower case letters indicate the state of the referenced input (or output) one set-up time prior to the LOW to HIGH clock transition.

SN54/74LS195A

GUARANTEED OPERATING RANGES

| Symbol | Parameter | | Min | Typ | Max | Unit |
|-----------------|-------------------------------------|--------|------|-----|------|------|
| V _{CC} | Supply Voltage | 54 | 4.5 | 5.0 | 5.5 | V |
| | | 74 | 4.75 | 5.0 | 5.25 | |
| T _A | Operating Ambient Temperature Range | 54 | -55 | 25 | 125 | °C |
| | | 74 | 0 | 25 | 70 | |
| I _{OH} | Output Current — High | 54, 74 | | | -0.4 | mA |
| I _{OL} | Output Current — Low | 54 | | | 4.0 | mA |
| | | 74 | | | 8.0 | |

DC CHARACTERISTICS OVER OPERATING TEMPERATURE RANGE (unless otherwise specified)

| Symbol | Parameter | Limits | | | Unit | Test Conditions | |
|-----------------|--------------------------------|--------|-------|------|------|--|---|
| | | Min | Typ | Max | | | |
| V _{IH} | Input HIGH Voltage | 2.0 | | | V | Guaranteed Input HIGH Voltage for All Inputs | |
| V _{IL} | Input LOW Voltage | 54 | | 0.7 | V | Guaranteed Input LOW Voltage for All Inputs | |
| | | 74 | | 0.8 | | | |
| V _{IK} | Input Clamp Diode Voltage | | -0.65 | -1.5 | V | V _{CC} = MIN, I _{IN} = -18 mA | |
| V _{OH} | Output HIGH Voltage | 54 | 2.5 | 3.5 | V | V _{CC} = MIN, I _{OH} = MAX, V _{IN} = V _{IH} or V _{IL} per Truth Table | |
| | | 74 | 2.7 | 3.5 | V | | |
| V _{OL} | Output LOW Voltage | 54, 74 | | 0.25 | 0.4 | V | I _{OL} = 4.0 mA V _{CC} = V _{CC} MIN, V _{IN} = V _{IL} or V _{IH} per Truth Table |
| | | 74 | | 0.35 | 0.5 | V | |
| I _{IH} | Input HIGH Current | | | 20 | μA | V _{CC} = MAX, V _{IN} = 2.7 V | |
| | | | | 0.1 | mA | V _{CC} = MAX, V _{IN} = 7.0 V | |
| I _{IL} | Input LOW Current | | | -0.4 | mA | V _{CC} = MAX, V _{IN} = 0.4 V | |
| I _{OS} | Short Circuit Current (Note 1) | -20 | | -100 | mA | V _{CC} = MAX | |
| I _{CC} | Power Supply Current | | | 21 | mA | V _{CC} = MAX | |

Note 1: Not more than one output should be shorted at a time, nor for more than 1 second.

AC CHARACTERISTICS (T_A = 25°C)

| Symbol | Parameter | Limits | | | Unit | Test Conditions |
|--------------------------------------|---------------------------------------|--------|----------|----------|------|---|
| | | Min | Typ | Max | | |
| f _{MAX} | Maximum Clock Frequency | 30 | 39 | | MHz | V _{CC} = 5.0 V C _L = 15 pF |
| t _{PLH} t _{PHL} | Propagation Delay, Clock to Output | | 14 17 | 22 26 | ns | |
| t _{PHL} | Propagation Delay, MR to Output | | 19 | 30 | ns | |

AC SETUP REQUIREMENTS (T_A = 25°C)

| Symbol | Parameter | Limits | | | Unit | Test Conditions |
|------------------|----------------------|--------|-----|-----|------|-------------------------|
| | | Min | Typ | Max | | |
| t _W | CP Clock Pulse Width | 16 | | | ns | V _{CC} = 5.0 V |
| t _W | MR Pulse Width | 12 | | | ns | |
| t _S | PE Setup Time | 25 | | | ns | |
| t _S | Data Setup Time | 15 | | | ns | |
| t _{rec} | Recovery Time | 25 | | | ns | |
| t _{rel} | PE Release Time | | | 10 | ns | |
| t _h | Data Hold Time | 0 | | | ns | |

SN54/74LS195A

DEFINITIONS OF TERMS

SETUP TIME (t_s) — is defined as the minimum time required for the correct logic level to be present at the logic input prior to the clock transition from LOW to HIGH in order to be recognized and transferred to the outputs.

HOLD TIME (t_h) — is defined as the minimum time following the clock transition from LOW to HIGH that the logic level must be maintained at the input in order to ensure continued

recognition. A negative HOLD TIME indicates that the correct logic level may be released prior to the clock transition from LOW to HIGH and still be recognized.

RECOVERY TIME (t_{rec}) — is defined as the minimum time required between the end of the reset pulse and the clock transition from LOW to HIGH in order to recognize and transfer HIGH Data to the Q outputs.

AC WAVEFORMS

The shaded areas indicate when the input is permitted to change for predictable output performance.

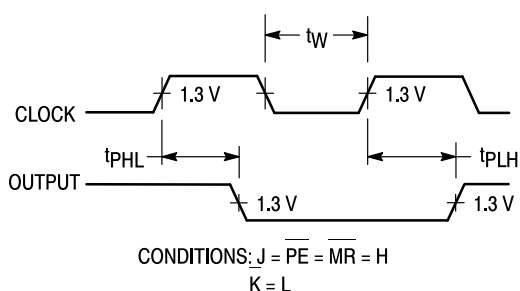

Figure 1. Clock to Output Delays and Clock Pulse Width

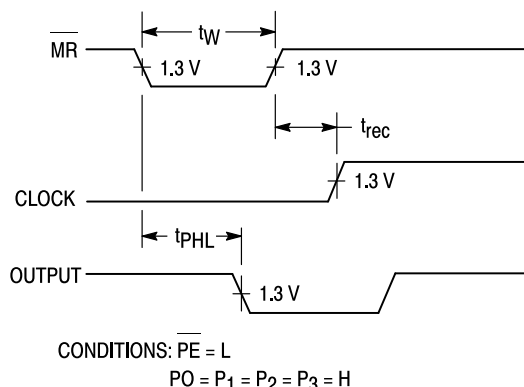

Figure 2. Master Reset Pulse Width, Master Reset to Output Delay and Master Reset to Clock Recovery Time

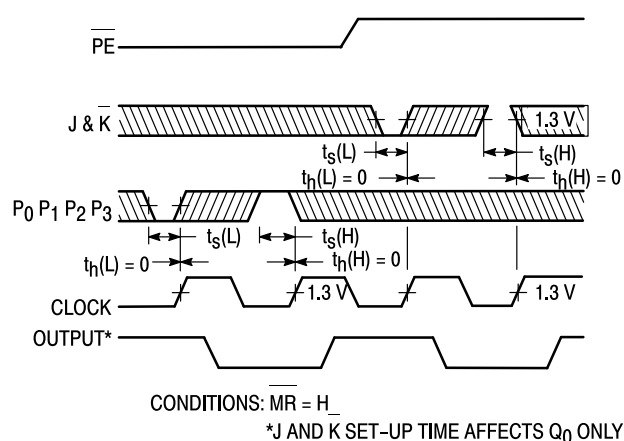

Figure 3. Setup (t_s) and Hold (t_h) Time for Serial Data (J & K) and Parallel Data (P_0 , P_1 , P_2 , P_3)

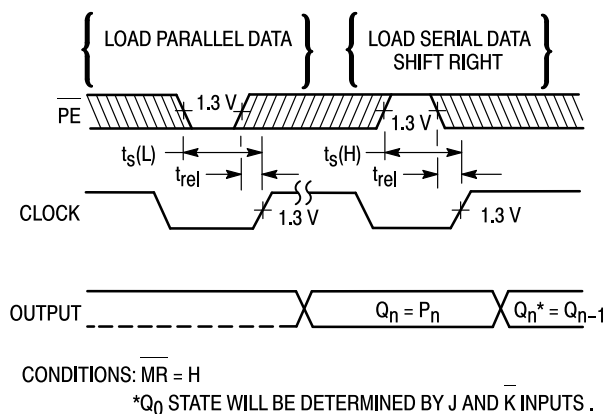
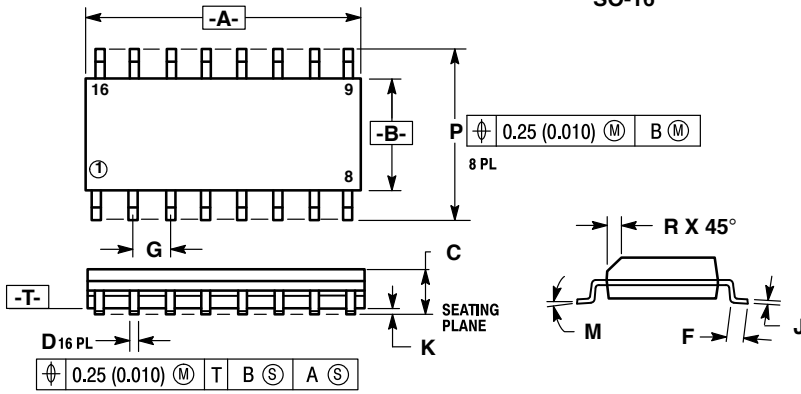

Figure 4. Setup (t_s) and Hold (t_h) Time for \overline{PE} Input

**Case 751B-03 D Suffix
16-Pin Plastic
SO-16**



- NOTES:
1. DIMENSIONING AND TOLERANCING PER ANSI Y14.5M, 1982.
 2. CONTROLLING DIMENSION: MILLIMETER.
 3. DIMENSION A AND B DO NOT INCLUDE MOLD PROTRUSION.
 4. MAXIMUM MOLD PROTRUSION 0.15 (0.006) PER SIDE.
 5. 751B-01 IS OBSOLETE, NEW STANDARD 751B-03.

| DIM | MILLIMETERS | | INCHES | |
|-----|-------------|-------|-----------|-------|
| | MIN | MAX | MIN | MAX |
| A | 9.80 | 10.00 | 0.386 | 0.393 |
| B | 3.80 | 4.00 | 0.150 | 0.157 |
| C | 1.35 | 1.75 | 0.054 | 0.068 |
| D | 0.35 | 0.49 | 0.014 | 0.019 |
| F | 0.40 | 1.25 | 0.016 | 0.049 |
| G | 1.27 BSC | | 0.050 BSC | |
| J | 0.19 | 0.25 | 0.008 | 0.009 |
| K | 0.10 | 0.25 | 0.004 | 0.009 |
| M | 0° | 7° | 0° | 7° |
| P | 5.80 | 6.20 | 0.229 | 0.244 |
| R | 0.25 | 0.50 | 0.010 | 0.019 |

**Case 648-08 N Suffix
16-Pin Plastic**

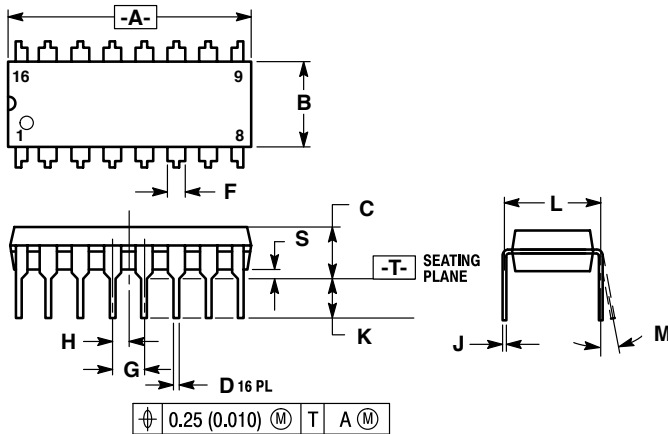

- NOTES:
1. DIMENSIONING AND TOLERANCING PER ANSI Y14.5M, 1982.
 2. CONTROLLING DIMENSION: INCH.
 3. DIMENSION "L" TO CENTER OF LEADS WHEN FORMED PARALLEL.
 4. DIMENSION "B" DOES NOT INCLUDE MOLD FLASH.
 5. ROUNDED CORNERS OPTIONAL.
 6. 648-01 THRU -07 OBSOLETE, NEW STANDARD 648-08.

| DIM | MILLIMETERS | | INCHES | |
|-----|-------------|-------|-----------|-------|
| | MIN | MAX | MIN | MAX |
| A | 18.80 | 19.55 | 0.740 | 0.770 |
| B | 6.35 | 6.85 | 0.250 | 0.270 |
| C | 3.69 | 4.44 | 0.145 | 0.175 |
| D | 0.39 | 0.53 | 0.015 | 0.021 |
| F | 1.02 | 1.77 | 0.040 | 0.070 |
| G | 2.54 BSC | | 0.100 BSC | |
| H | 1.27 BSC | | 0.050 BSC | |
| J | 0.21 | 0.38 | 0.008 | 0.015 |
| K | 2.80 | 3.30 | 0.110 | 0.130 |
| L | 7.50 | 7.74 | 0.295 | 0.305 |
| M | 0° | 10° | 0° | 10° |
| S | 0.51 | 1.01 | 0.020 | 0.040 |

**Case 620-09 J Suffix
16-Pin Ceramic Dual In-Line**

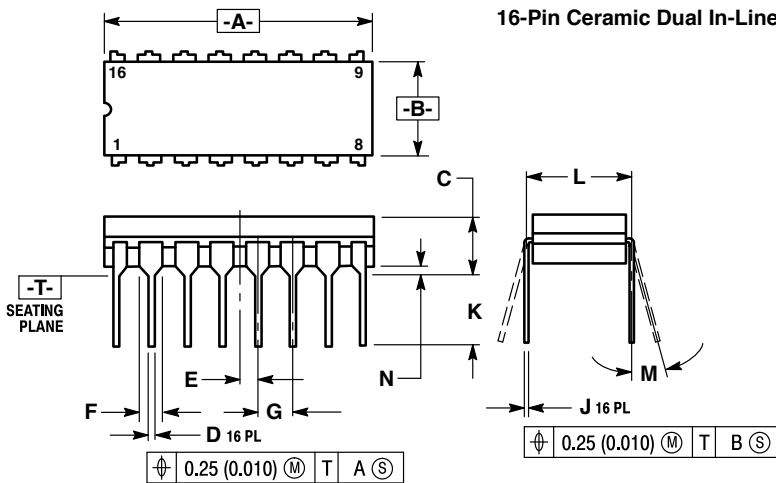

- NOTES:
1. DIMENSIONING AND TOLERANCING PER ANSI Y14.5M, 1982.
 2. CONTROLLING DIMENSION: INCH.
 3. DIMENSION L TO CENTER OF LEAD WHEN FORMED PARALLEL.
 4. DIM F MAY NARROW TO 0.76 (0.030) WHERE THE LEAD ENTERS THE CERAMIC BODY.
 5. 620-01 THRU -08 OBSOLETE, NEW STANDARD 620-09.

| DIM | MILLIMETERS | | INCHES | |
|-----|-------------|-------|-----------|-------|
| | MIN | MAX | MIN | MAX |
| A | 19.05 | 19.55 | 0.750 | 0.770 |
| B | 6.10 | 7.36 | 0.240 | 0.290 |
| C | — | 4.19 | — | 0.165 |
| D | 0.39 | 0.53 | 0.015 | 0.021 |
| E | 1.27 BSC | | 0.050 BSC | |
| F | 1.40 | 1.77 | 0.055 | 0.070 |
| G | 2.54 BSC | | 0.100 BSC | |
| J | 0.23 | 0.27 | 0.009 | 0.011 |
| K | — | 5.08 | — | 0.200 |
| L | 7.62 BSC | | 0.300 BSC | |
| M | 0° | 15° | 0° | 15° |
| N | 0.39 | 0.88 | 0.015 | 0.035 |

Motorola reserves the right to make changes without further notice to any products herein. Motorola makes no warranty, representation or guarantee regarding the suitability of its products for any particular purpose, nor does Motorola assume any liability arising out of the application or use of any product or circuit, and specifically disclaims any and all liability, including without limitation consequential or incidental damages. "Typical" parameters can and do vary in different applications. All operating parameters, including "Typicals" must be validated for each customer application by customer's technical experts. Motorola does not convey any license under its patent rights nor the rights of others. Motorola products are not designed, intended, or authorized for use as components in systems intended for surgical implant into the body, or other applications intended to support or sustain life, or for any other application in which the failure of the Motorola product could create a situation where personal injury or death may occur. Should Buyer purchase or use Motorola products for any such unintended or unauthorized application, Buyer shall indemnify and hold Motorola and its officers, employees, subsidiaries, affiliates, and distributors harmless against all claims, costs, damages, and expenses, and reasonable attorney fees arising out of, directly or indirectly, any claim of personal injury or death associated with such unintended or unauthorized use, even if such claim alleges that Motorola was negligent regarding the design or manufacture of the part. Motorola and TM are registered trademarks of Motorola, Inc. Motorola, Inc. is an Equal Opportunity/Affirmative Action Employer.

Literature Distribution Centers:

USA: Motorola Literature Distribution; P.O. Box 20912; Phoenix, Arizona 85036.

EUROPE: Motorola Ltd.; European Literature Centre; 88 Tanners Drive, Blakelands, Milton Keynes, MK14 5BP, England.

JAPAN: Nippon Motorola Ltd.; 4-32-1, Nishi-Gotanda, Shinagawa-ku, Tokyo 141, Japan.

ASIA PACIFIC: Motorola Semiconductors H.K. Ltd.; Silicon Harbour Center, No. 2 Dai King Street, Tai Po Industrial Estate, Tai Po, N.T., Hong Kong.



This datasheet has been download from:

www.datasheetcatalog.com

Datasheets for electronics components.