



## Estimation of the freezing point of concentrated fruit juices for application in freeze concentration

J.M. Auleda, M. Raventós\*, J. Sánchez, E. Hernández

Agri-Food Engineering and Biotechnology Department, Technical University of Catalonia (UPC), C/ Esteve Terradas, 8, 08860 Castelldefels (Barcelona), Spain

### ARTICLE INFO

#### Article history:

Received 21 October 2010

Received in revised form 10 January 2011

Accepted 18 February 2011

Available online 23 February 2011

#### Keywords:

Fruit juice

Freezing point

Freeze concentration

Sugars

### ABSTRACT

In freeze concentration operations the fluids remain at temperatures below 0 °C. For a good study of this concentration operation is very important to know the values of freezing point. The aim of this work was to establish a model that predicts the freezing point of fruit juices at various concentrations within the range of interest for freeze concentration (10–40 °Brix). The model proposed relates the freezing point of a juice with the concentrations of main sugars present in the juice: sucrose, glucose and fructose. The freezing point of apple juice, pear juice and peach juice was determined experimentally at various concentrations, and experimental results were well correlated with model calculations.

© 2011 Elsevier Ltd. All rights reserved.

### 1. Introduction

Juices are of great importance in the fruit processing industry. During processing, the juices are subjected to various operations, such as cold storage or freezing and concentration. The latter operation is performed in order to reduce transport costs and increase shelf life.

The juices are usually concentrated by evaporation, but the high processing temperatures used are known to damage heat-sensitive components and reduce the organoleptic properties of the juice (Chin et al., 2009; Polydera et al., 2003). Therefore membrane techniques are used as a first concentration step in some industrial applications.

Freeze concentration process has been widely studied (Auleda et al., 2009). This technique involves the removal of water as ice crystals by cooling the fluid to be concentrated at temperatures below the freezing point (Raventós et al., 2007; Hernandez et al., 2010). The concentration of juices using this technique has proven highly efficient in maintaining the organoleptic properties and vitamin C (Braddock and Marcy, 1985, 1987; Liu et al., 1999; Ramos et al., 2005). According to Sánchez et al. (2009) the concentrations achieved for fruit juices are around 30 °Brix for plate-based systems and between 45 and 55 °Brix for systems based on suspension crystallisation.

Several researchers state that the freezing point and viscosity of the fluid to be concentrated are the main variables for the freeze

concentration process (Heldman and Lund, 1992). This is partly because these variables have a direct influence on the efficiency of the process and partly because other important parameters can be calculated based on the freezing point and viscosity. A number of correlations have been published that relate physical properties such as the density of the ice formed, the carbohydrate density, the specific heat and the thermal conductivity to freezing point and viscosity (Choi and Okos, 1986; Chen and Chen, 2000).

These physical properties are of importance to study the freeze concentration process and to design or scale-up equipments.

The viscosity of concentrated juices can be predicted by correlations similar to the Arrhenius-equation which predict the dependence on temperature (Saravacos, 1970; Rao et al., 1984; Ibarz et al., 1994, 1996) or both the dependence on temperature and on concentration (Ibarz et al., 2009). In this work a model has been established to predict the freezing point of fruit juices. This data could be used for calculation of the freeze concentration process.

### 2. Material and methods

#### 2.1. Analysis of the fruit juices

The levels of fructose, glucose and sucrose in the fruit juices were determined by high resolution liquid chromatography (Beckman HPLC, San Ramon) with a Spherisorb NH<sub>2</sub> column (25 × 0.4 cm), and with acetonitrile: water (75:25) as mobile phase. The flow rate was 1.5 mL per minute and the injection volume was 20 µL. Analyses were performed in triplicate and were expressed as mass%.

\* Corresponding author. Tel.: +34 935521000.

E-mail address: [merce.raventos@upc.edu](mailto:merce.raventos@upc.edu) (M. Raventós).

## 2.2. Preparation of samples for freezing point determination

Concentrated clarified and depectinized juices of peach, apple and pear were used in this study. The juices had initial concentrations of 70 °Brix and had been produced by multiple-effect evaporation with mechanical vapour recompression. They were supplied by Nufri (Lleida, Spain). From these juices dilutions of 10, 15, 20, 25, 30, 35 and 40 °Brix were prepared with distilled water.

The concentration of soluble solids in the samples was measured with a refractometer (Atago DBX-55, Japan) at a temperature of  $20 \pm 0.5$  °C. Samples were kept refrigerated at 2 °C until the start of the trials.

## 2.3. Installation and experimental method for freezing point determination

The experimental set up used (Fig. 1) consist of four closed test tubes (1) with 10 mL of sample. These were immersed in a cryostat (POLYSCIENCE model 9505 – United States; temperature range:  $-30$  to  $150$  °C; temperature stability:  $\pm 0.05$  °C; readout accuracy:  $\pm 0.5$  °C) (2), filled with a mixture of laboratory grade ethylene glycol and water at  $-10$  °C (3). Thermocouples type K contact probe (4) with a NiCr–NiAl sensor with precision of  $\pm 0.7$  °C and a measurement range of  $-50$  to  $1000$  °C (previously calibrated with distilled water) were placed inside each test tube (5). The probes were connected to a data logger “Testo Comfort Software Basic” (6) that recorded temperature every 15 s storing data on a computer (7). For each test the four tubes were filled with the same liquid, so that results were obtained in quadruple.

## 2.4. Verification of the method for determining the freezing point

The freezing point of sucrose, glucose and fructose was determined. Experimental results were then compared with literature data.

The sugars used were:

D(–)-fructose, purity at least 99.5%, Sigma

D(+)-glucose anhydrous, purity 99.0%, A-ACS Panreac Quimica, SA

Sucrose (cane sugar), purity at least 99.5%.

After calibrating the probes with distilled water, the freezing points of fructose, glucose and sucrose were obtained, as described above. The values obtained were corrected to the values found in literature (Lide, 1995).

## 2.5. Models for predicting the freezing point

Chen (1986) presented two general models for predicting the freezing point of solutions (1 and 2):

Model 1 – for ideal solutions (Schwartzberg, 1976)

$$M_S = \frac{KX_S}{(1 - X_S) \cdot \Delta t} \quad (1)$$

where  $M_S$  is the molecular weight of the solute,  $X_S$  is the mass fraction of solute in kg/kg solution,  $K$ ,  $1000 K_f$  and  $K_f$  is the molal freezing point depression that is constant for water ( $K_f = 1.86$  °C kg/mol),  $\Delta t$ , freezing point depression.

Model 2 – To correct for the non-ideal behaviour of solutions at higher concentrations, the variable  $b$  is introduced in the denominator of Eq. (1), as shown in Eq. (2).

$$M_S = \frac{KX_S}{(1 - X_S - bX_S) \cdot \Delta t} \quad (2)$$

where  $b$  is a variable to correct the non-ideal behaviour.

This last equation contains two unknown variables ( $M_S$  and  $b$ ), which can be determined when two pairs of  $X_S$  and  $\Delta t$  values are known, which should be chosen at concentrations of approximately 10% and 30%. For juices, which contain various solutes with different molecular weight, the value of  $M_S$  determined by this approach is called the Effective Molecular Weight (EMW, kg/kmol) of the juice.

Model 3, described by Chen et al. (1996) modifies the previous model and introduces  $C$  as “concentration coefficient”:

$$M_S = \frac{KX_S(1 + CX_S)}{(1 - X_S) \cdot \Delta t} \quad (3)$$

Model 1 should not be used to predict the FPD of fruit juices, because fruit juices do not show ideal behaviour. This model would only be appropriate for dilute solutions of fruit juices with sugar concentrations below 10%

Models 2 and 3 can be used to make predictions of the FPD of juices at various concentrations, once the FPD is known for two concentrations, around 10% and 30%. Unfortunately, for most juices these data are not available.

## 3. Results and discussion

### 3.1. Composition of the juices

Table 1 shows the results for the relative concentrations of the three most important sugars in the juices, obtained by HPLC.

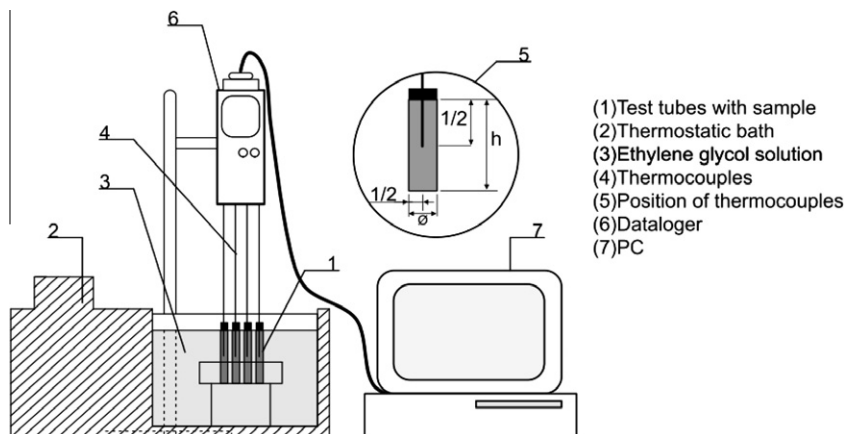

Fig. 1. Experimental set-up for measuring freezing point depression.

Based on the relative concentrations of the sugars in the juice, the equivalent molecular weight of each juice can be calculated by the following equation:

$$p_f = \frac{\%f \cdot mf}{100} \quad p_g = \frac{\%g \cdot mg}{100} \quad p_s = \frac{\%s \cdot ms}{100}$$

$$M_{sequi} = p_f + p_g + p_s \quad (4)$$

where %f, %g, and %s are the percentage of fructose, glucose, and sucrose respectively, obtained from HPLC analysis. mf, mg and ms, are the molecular weight of fructose, glucose and sucrose respectively, which are 180.16, 180.16 and 342.3 g/mol.  $M_{sequi}$  is the equivalent molecular weight of the juice. Based on the values in Table 1, the following equivalent molecular weights are obtained for the apple juice, pear juice and peach juice tested (g/mol):

$$M_{sequi,Apple} = 206 \text{ g/mol}$$

$$M_{sequi,Pear} = 194 \text{ g/mol}$$

$$M_{sequi,Peach} = 271 \text{ g/mol}$$

3.2. Freezing point ( $\Delta T_f$ )

The freezing points at various concentrations were determined based on the cooling curves of each sample, as shown in Fig. 2.

The lowest temperature of the freezing curve indicates the beginning of the formation of ice crystals (nucleation). This is followed by a temperature increase due to the latent heat of the phase change. The highest temperature reached after this temperature increase is the freezing point of the sample, associated with the growth stage of ice crystals (crystallization). The difference between the freezing point and the lowest temperature reached is called subcooling. The freezing points at different concentrations expressed in °Brix are shown in Table 2 and Fig. 3.

As expected, the freezing point of the juices decreases with increasing concentration. The differences observed between the juices are attributed to (1) differences in relative concentrations of the three main sugars (fructose, glucose and sucrose), (2) differences in total solid concentrations, and (3) other characteristics of the juices, not explicitly considered.

- (a) Values calculated by Eq. (2),  $b = 0.14$  and  $M_S = 180.16$
- (b) Values calculated by Eq. (2),  $b = 0.18$  and  $M_S = 180.16$
- (c) Values calculated by Eq. (2),  $b = 0.28$  and  $M_S = 342.3$

Fig. 4 shows the curves for freezing point versus concentration obtained for apple juice, pear juice and peach juice compared to the theoretical upper limit (sucrose) and lower limit (glucose). It is clear from this graph that the curve for peach juice is relatively close to that of sucrose, which corresponds to the relatively high level of sucrose present in peach juice. On the other hand, the curve of pear juice is relatively close to that of glucose, which corresponds to the relatively high level of monosaccharides present in pear juice.

3.3. Determining the correlation

The results of Fig. 4 indicate that the proportion of monosaccharides to disaccharides plays a determining factor in the relation

**Table 1**  
Proportion of sugars in fruit juices.

%	Peach	Apple	Pear
Glucose	18.80 ± 0.20	22.00 ± 0.16	39.00 ± 0.30
Fructose	25.50 ± 0.15	62.00 ± 0.22	52.50 ± 0.03
Sucrose	55.70 ± 0.25	16.00 ± 0.30	8.50 ± 0.40

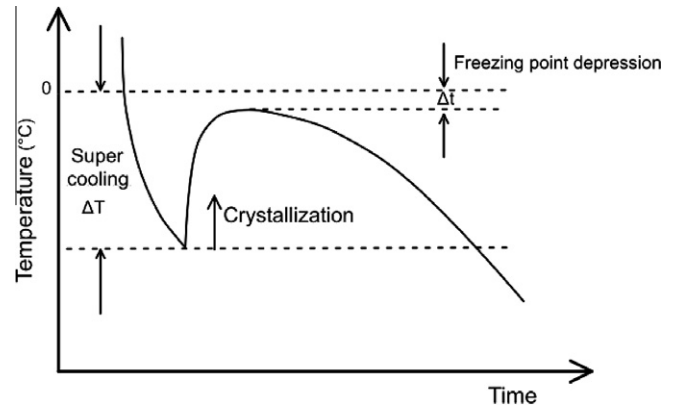

Fig. 2. Schematic diagram of cooling curve.

**Table 2**  
Freezing points versus concentration for pear juice, apple juice and peach juice.

°Brix	Apple juice T (°C)	Pear juice T (°C)	Peach juice T (°C)
10	-1.07	-1.05	-1.00
15	-1.74	-1.80	-1.60
20	-2.50	-2.50	-2.05
25	-3.20	-3.60	-2.70
30	-4.10	-4.30	-3.25
35	-5.20	-5.50	-4.20
40	-6.70	-6.60	-5.60

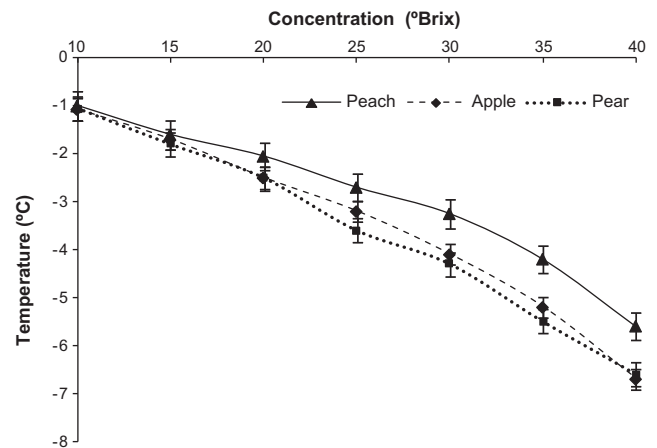

Fig. 3. Freezing point as function of concentration for apple juice, pear juice and peach juice.

between freezing point and concentration. Based on this finding, a correlation is proposed that predicts freezing point for each juice as a function of the equivalent molecular weight of the juice compared to the molecular weights of glucose and sucrose.

$$\frac{M_{S-S} - M_{S-G}}{M_{S-m} - M_{S-G}} = \frac{T_{S,Bx} - T_{G,Bx}}{T_{m,Bx} - T_{G,Bx}} \quad (5)$$

where  $M_{S-S}$ ,  $M_{S-G}$ , and  $M_{S-m}$  are respectively the molecular weights of sucrose, D-glucose and the juice studied obtained by Eq. (4).  $T_{S,Bx}$  and  $T_{G,Bx}$  are respectively the freezing points of sucrose and glucose at the concentration (°Brix) of interest (Chen, 1986).  $T_{m,Bx}$  is the estimation of the freezing point at the concentration (°Brix) of interest.

In the following sections the results are presented for the freezing points of apple juice, pear juice, and peach juice based on Eq. (5) and the values of Table 3.

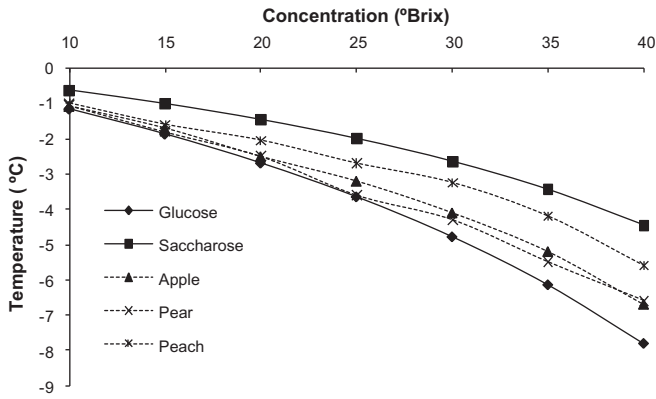

Fig. 4. Freezing point of the juices compared to the theoretical upper limit (sucrose) and lower limit (glucose).

Table 3  
Freezing point of D-fructose, D-glucose and sucrose at various concentrations.

°Brix	Fructose (a)	Glucose (b)	Sucrose (c)
10	-1.165	-1.171	-0.623
15	-1.868	-1.882	-1.009
20	-2.675	-2.703	-1.461
25	-3.610	-3.661	-1.998
30	-4.707	-4.794	-2.646
35	-6.012	-6.156	-3.445
40	-7.591	-7.821	-4.454

3.3.1. Apple juice

Fig. 5 and Table 4 show the results of applying Eq. (5) for Apple juice. It is clear that the equation gives a very good prediction for concentrations up to 25 °Brix and a fair prediction for concentrations up to 40 °Brix. The standard deviation of the whole set is  $S_{apple} = 0.34$  °C.

3.3.2. Pear juice

Fig. 6 and Table 5 show the results of applying Eq. (5) for pear juice. It is clear that the equation gives a good prediction for concentrations up to 25 °Brix and a fair prediction for concentrations up to 40 °Brix. The standard deviation of the whole set is  $S_{pear} = 0.44$  °C.

3.3.3. Peach juice

Fig. 7 and Table 6 show the results of applying Eq. (5) for peach juice. It is clear that the equation gives a fair prediction for the whole range of concentrations up to 40 °Brix. The standard deviation of the whole set is  $S_{peach} = 0.29$  °C.

Fig. 8 shows the freezing points of glucose and sucrose. The freezing point of any juice should be in the area between the two curves. A good fit is obtained with the proposed model. The estimated freezing point values are very similar to those obtained experimentally for juices studied. Similar errors were obtained by Chen (1988) in a model to estimate the freezing point of orange juice. Shamsudin et al. (2005), provides the following experimental measured values for guava juice: 10 °Brix, glucose (%)  $1.38 \pm 0.15$ ; fructose (%)  $1.66 \pm 0.11$ ; sucrose (%)  $0.74 \pm 0.01$  and freezing point (°C)  $-1.07 \pm 0.02$ . With these data, the freezing point of guava juice have been estimated using the proposed correlation. A freezing point of  $-1.06$  °C has been obtained and this value is agree with the experimental one.

Similar models for estimating the freezing point of fruit juices have not been found in the literature. Different freezing points values for fruit juices have been consulted. These values are in what

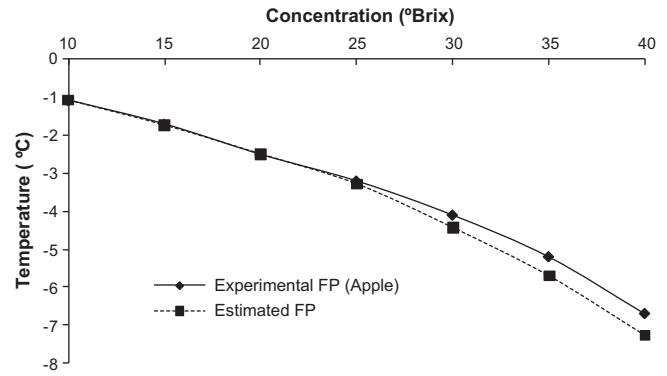

Fig. 5. Freezing points of apple juice calculated using Eq. (5) compared with experimental results.

Table 4  
Freezing points of apple juice calculated using Eq. (5) compared with experimental results.

°Brix	$T_{m}$ measured ( $t_m$ (°C))	$T_{est}$ estimated ( $t_{est}$ (°C))	$ t_{est} - t_m $	% Error
10	-1.07	-1.08	0.01	0.93
15	-1.74	-1.74	0.00	0.00
20	-2.50	-2.50	0.00	0.00
25	-3.20	-3.29	0.09	2.81
30	-4.10	-4.44	0.34	8.29
35	-5.20	-5.71	0.51	9.81
40	-6.70	-7.28	0.58	8.66

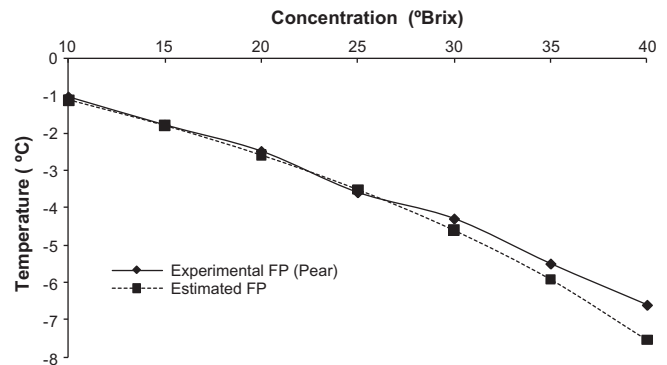

Fig. 6. Freezing points of pear juice calculated using Eq. (5) compared with experimental results.

Table 5  
Freezing points of pear juice calculated using Eq. (5) compared with experimental results.

°Brix	$T_{m}$ measured ( $t_m$ (°C))	$T_{est}$ estimated ( $t_{est}$ (°C))	$ t_{est} - t_m $	% Error
10	-1.05	-1.12	0.07	6.67
15	-1.80	-1.81	0.01	0.56
20	-2.50	-2.60	0.10	4.00
25	-3.60	-3.52	0.08	2.22
30	-4.30	-4.61	0.31	7.21
35	-5.50	-5.92	0.42	7.64
40	-6.60	-7.54	0.94	14.24

has been called "juice zone" (area between the freezing point curves of glucose and sucrose) in Fig. 8. This fact has also been verified in tests of Telis and Telis-Romero (2007), Chen et al. (1990) and Lerici et al. (1983).

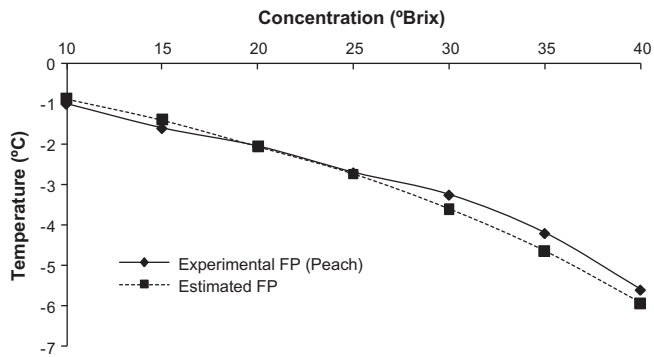

Fig. 7. Freezing points of peach juice calculated using Eq. (5) compared with experimental results.

**Table 6**  
Freezing points of peach juice calculated using Eq. (5) compared with experimental results.

°Brix	$T_{m}$ measured $t_m$ (°C)	$T$ estimated $t_{est}$ (°C)	$ t_{est} - t_m $	% Error
10	-1.00	-0.86	0.14	14.00
15	-1.60	-1.39	0.21	13.13
20	-2.05	-2.05	0.00	0.00
25	-2.70	-2.73	0.03	1.11
30	-3.25	-3.60	0.35	10.77
35	-4.20	-4.65	0.45	10.71
40	-5.60	-5.94	0.34	6.07

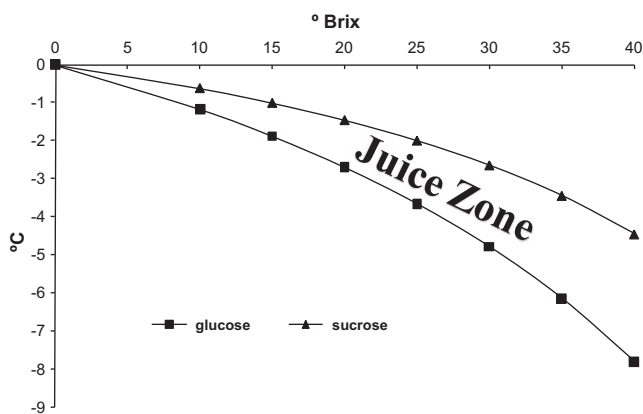

Fig. 8. Area of freezing points for juices.

#### 4. Conclusions

Based on the relative concentrations of sugars (glucose, fructose and sucrose) present in a juice, an equivalent molecular weight can be calculated for the juice. A correlation was proposed to estimate the freezing point of the juice based on this equivalent molecular weight. The main use of the correlation is: for a particular concentration (10–40 °Brix) the FPD at this concentration can be get.

When plotting the curves of freezing point versus concentration (in °Brix), it was found that the curves for apple juice, pear juice and peach juice are in the area between the curves for sucrose (a disaccharide) and glucose (a monosaccharide). It is assumed that the same behaviour will be observed for all other juices.

When comparing the freezing points calculated by the correlation proposed in this work with experimental results, the standard deviations for all the observations in the range of 10–40 °Brix were

0.34, 0.44 and 0.29 °C for apple juice, pear juice and peach juice, respectively.

The relative errors in the freezing points calculated for the juices studied show generally values lower than 5% in the region of 15–25 °Brix and values of about 10% in the area of 25–40 °Brix. These differences are considered acceptable for performing engineering calculations and in pre-studies on a freeze concentration process. The estimates in this study have yielded correlations as a function of temperature and this will provide useful information in the study of freeze concentration.

#### Acknowledgements

José Sánchez acknowledges the “Fondo Nacional de Ciencia y Tecnología” (FONACIT) of the Bolivarian Republic of Venezuela for a grant awarded to perform his doctoral studies abroad (2008–2012).

The authors acknowledge the juice company Nufri (Mollerusa-Spain) which provided the juices tested.

#### References

- Auleda, J.M., Hernández, E., Raventós, M., 2009. Criocentración de fluidos alimentarios: una tecnología emergente? *Tecnología i Ciència dels Aliments (TECA)* 11 (2), 12–18.
- Braddock, R.J., Marcy, J.E., 1985. Freeze concentration of pineapple juice. *Journal of Food Science* 50, 1636–1639.
- Braddock, R.J., Marcy, J.E., 1987. Quality of freeze concentrated orange juice. *Journal of Food Science* 52, 159–162.
- Chen, P., Chen, X.D., 2000. A generalized correlation of solute inclusion in ice formed from aqueous solutions and food liquids on sub-cooled surface. *The Canadian Journal of Chemical Engineering* 78, 312–319.
- Chen, C.S., Nguyen, T.K., Braddock, R.J., 1990. Relationship between freezing point depression and solute composition of fruit juice systems. *Journal of Food Science* 55 (2), 566–569.
- Chen, Ping., Chen, Xiao., Dong, Free., Kevin, W., 1996. Measurement and data interpretation of the freezing point depression of milks. *Journal of Food Engineering* 30, 239–253.
- Chen, C.S., 1986. Effective molecular weight of aqueous solutions and liquid foods calculated from the freezing point depression. *Journal of food Science* 51 (6), 1537–1553.
- Chen, C.S., 1988. Bound water and freezing point depression of concentrated orange juices. *Journal of Food Science* 53, 983–984.
- Chin, N.L., Chan, S.M., Yusof, Y.A., Chuah, T.G., Talib, R.A., 2009. Modelling of rheological behaviour of pummelo juice concentrates using master-curve. *Journal of Food Engineering* 93, 134–140.
- Choi, Y., Okos, M.R., 1986. Effect of temperature and composition on the thermal properties of foods. In: Le Maguer, M., Jelen, P. (Eds.), *Food Engineering and Process Applications*. Elsevier, London, pp. 93–101.
- Heldman, D.R., Lund, D.B., 1992. *Handbook of Food Engineering*. Marcel Dekker, Inc., New York.
- Hernandez, E., Raventós, M., Auleda, J.M., Ibarz, A., 2010. Freeze concentration of must in a pilot plant falling film cryoconcentrator. *Innovative Food Science and Emerging Technologies* 11, 130–136.
- Ibarz, A., González, C., Esplugas, S., 1994. Rheology of clarified fruit juices. III: orange juices. *Journal of Food Engineering* 21, 485–494.
- Ibarz, A., Garvin, A., Costa, J., 1996. Rheological behavior of sloe (*Prunus spinosa*) fruit juices. *Journal of Food Engineering* 27, 423–430.
- Ibarz, R., Falguera, V., Garvín, A., Garza, S., Pagán, J., Ibarz, A., 2009. Flow behavior of clarified orange juice at low temperatures. *Journal of Texture Studies* 40, 445–456.
- Leric, C.R., Piva, M., Dalla Rosa, M., 1983. Water activity and freezing point depression of aqueous solutions and liquid foods. *Journal of Food Science* 48, 1667–1669.
- Lide, D.R. (1995). *Handbook of Chemistry and Physics*, seventh ed., CRC Press.
- Liu, L., Miyawaki, O., Hayakawa, K., 1999. Progressive freeze concentration of tomato juice. *Food Science and Technology Research* 5, 108–112.
- Polydera, A.C., Stoforos, N.G., Taoukis, P.S., 2003. Comparative shelf life study and vitamin C loss kinetics in pasteurised and high pressure processed reconstituted orange juice. *Journal of Food Engineering* 60, 21–29.
- Ramos, F.A., Delgado, J.L., Bautista, E., Morales, A.L., Duque, C., 2005. Changes in volatiles with the application of progressive freeze-concentration to Andes berry (*Rubus glaucus Benth*). *Journal of Food Engineering* 69, 291–297.
- Rao, M.A., Cooley, H.J., Vitali, A.A., 1984. Flow properties of concentrated juice at low temperatures. *Food Technology* 38 (3), 113–119.
- Raventós, M., Hernández, E., Auleda, J.M., Ibarz, A., 2007. Concentration of aqueous sugar solutions in a multi-plate cryoconcentrator. *Journal of Food Engineering* 79, 577–585.

- Sánchez, J., Ruiz, Y., Auleda, J.M., Hernández, E., Raventós, M., 2009. Review. Freeze concentration in the fruit juices industry. *Food Science and Technology International* 15, 303–315.
- Saravacos, G.D., 1970. Effect of temperature on viscosity of fruit juices and purees. *Journal of Food Science* 35, 122–125.
- Schwartzberg, H.G., 1976. Effective heat capacities for the freezing and thawing of food. *Journal of Food Science* 41 (1), 152–156.
- Shamsudin, Rosnah, Mohamed, Ibrahim O., Mohd Yaman, Nor Khalillah, 2005. Thermophysical properties of Thai seedless guava juice as affected by temperature and concentration. *Journal of Food Engineering* 66, 395–399.
- Telis, V.R.N., Telis-Romero, J., 2007. Freezing point and thermal conductivity of tropical fruit pulps: mango and papaya. *International Journal of Food Properties* 10, 73–84.